

Features

- Wide Operating Voltage Range: 3V~8V
- Low noise output without external capacitor filtering
- Linearity $\pm 5\%$
- Temperature Grade 1: -40°C to 125°C
Ambient Operating Temperature Range
- Device HBM ESD Classification Level Class3B
- SOT23-3 package

Applications

- Potential Control
- Precise Position Detection
- Game Handle
- Flow Meter

General Description

The XL594 is a linear Hall sensor optimized for wide voltage and temperature ranges, with an output voltage that varies proportionally to the supply voltage, and proportional to the strength of the magnetic field it senses. The XL594's output voltage without magnetic field defaults to half of the supply voltage, the chip's typical operating voltage is 5.0V, with an ultimate withstand voltage of up to 50V, and a typical value of sensitivity of 1.6mV/Gs. The operating temperature range supports -40°C ~ 125°C . It is widely used in consumer and industrial control applications.

The XL594 integrates high precision current source, temperature compensation module, Hall array, amplifier, driver module and other circuit modules, which provides high linearity and strong immunity to electromagnetic interference over the full voltage range and full temperature range.

Typical application schematic

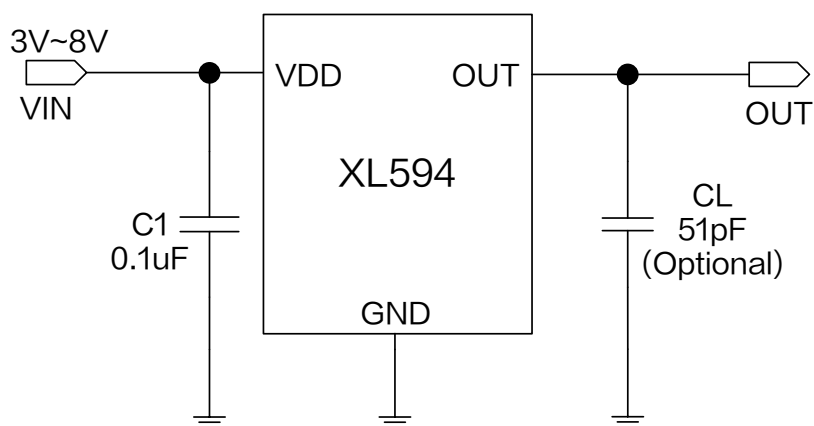

Figure1. XL594 Typical application schematic

Linear Hall Sensor

XL594

Pin Configurations

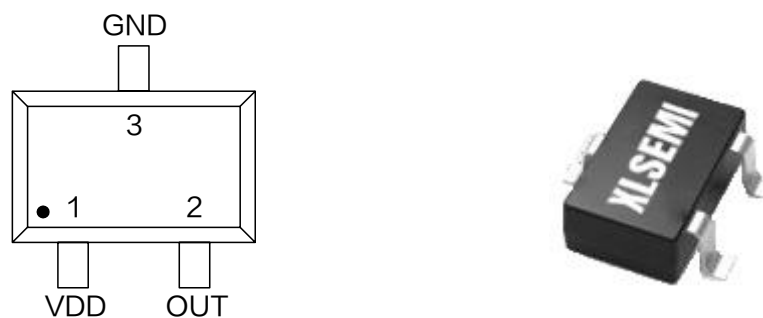

Figure2. Pin Configuration of XL594

Table 1 Pin Description

Pin Number	Pin Name	Description
1	VDD	Supply Voltage Input Pin. XL594 operates from 3V to 8V DC voltage.
2	OUT	Open Collector Output Pin, requires a resistor pull-up.
3	GND	Ground pin.

Ordering Information

Order Information	Marking ID	Package Type	Eco Plan	Packing Type Supplied As
XL594	XL594	SOT23-3	RoHS & HF	3000 Units Per Reel

Function Block

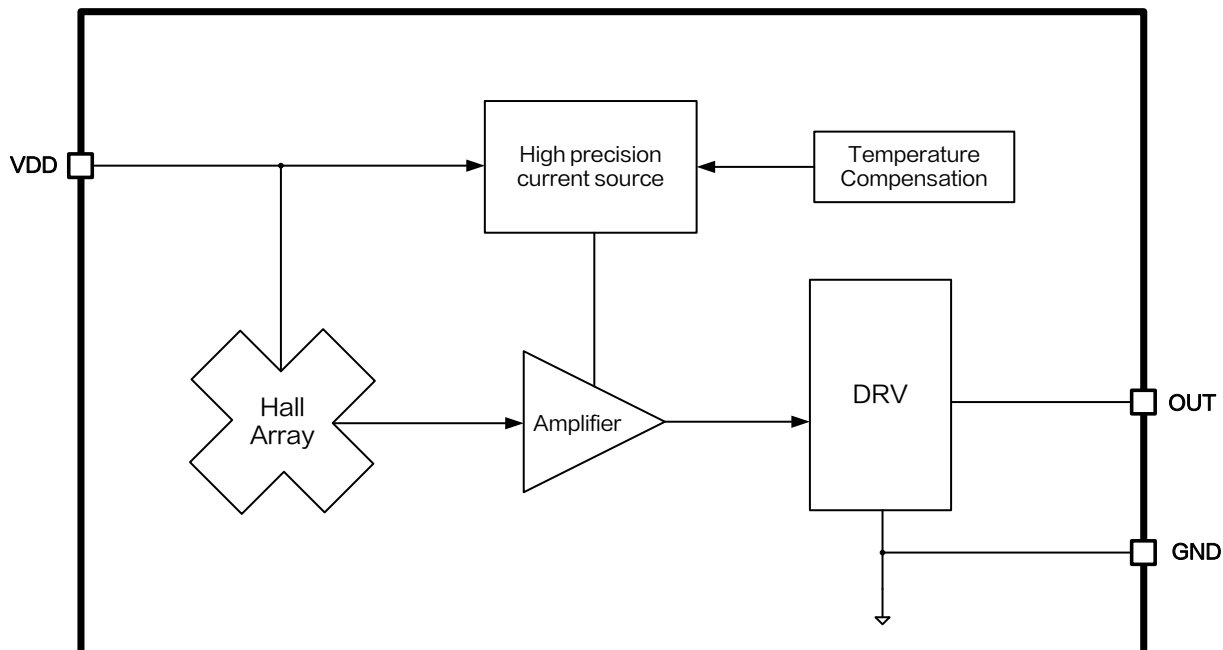

Figure3. Function Block Diagram of XL594

Absolute Maximum Ratings (Note1)

Parameter	Symbol	Value	Unit
Input Voltage	V_{DD}	-0.3 ~ 50	V
Output Pin Voltage	V_{OUT}	-0.3 ~ 40	V
Output Current	I_{OUT}	1	mA
Thermal Resistance (SOT23-3) (Junction to Ambient, No Heatsink, Free Air)	R_{JA}	200	°C/W
Operating Temperature	T_A	-40 ~ 125	°C
Operating Junction Temperature	T_J	-40 ~ 150	°C
Storage Temperature	T_{STG}	-65 ~ 150	°C
Lead Temperature (Soldering, 10 sec)	T_{LEAD}	260	°C
ESD (HBM)		>8000	V

Note1: Stresses greater than those listed under Maximum Ratings may cause permanent damage to the device. This is a stress rating only and functional operation of the device at these or any other conditions above those indicated in the operation is not implied. Exposure to absolute maximum rating conditions for extended periods may affect reliability.

Linear Hall Sensor

XL594

XL594 Electrical Characteristics (Note2)

$T_A = 25^\circ\text{C}$, $V_{DD} = 5\text{V}$; system parameters test circuit figure1, unless otherwise specified.

Parameters	Symbol	Test Condition	Min.	Typ.	Max.	Unit
Operation Voltage	V_{DD}		3		8	V
Operation Current	I_{DD}			6.5	10	mA
Output Load Resistance	R_L		2.5			k Ω
Output Voltage Range	$V_{OUT(H)}$		4.0	4.2		V
	$V_{OUT(L)}$			0.8	1.0	V
Static Output Voltage	$V_{OUT(Q)}$	$B=0\text{Gs}$, $R_L=10\text{k}\Omega$	2.4	2.5	2.6	V
Sensitivity	SENS		1.35	1.60	1.85	mV/Gs
Linearity	Lin		-5		5	%
Response Time	t_r			1		μs

Note2 : A south pole near the marked side of the package is a positive magnetic field.

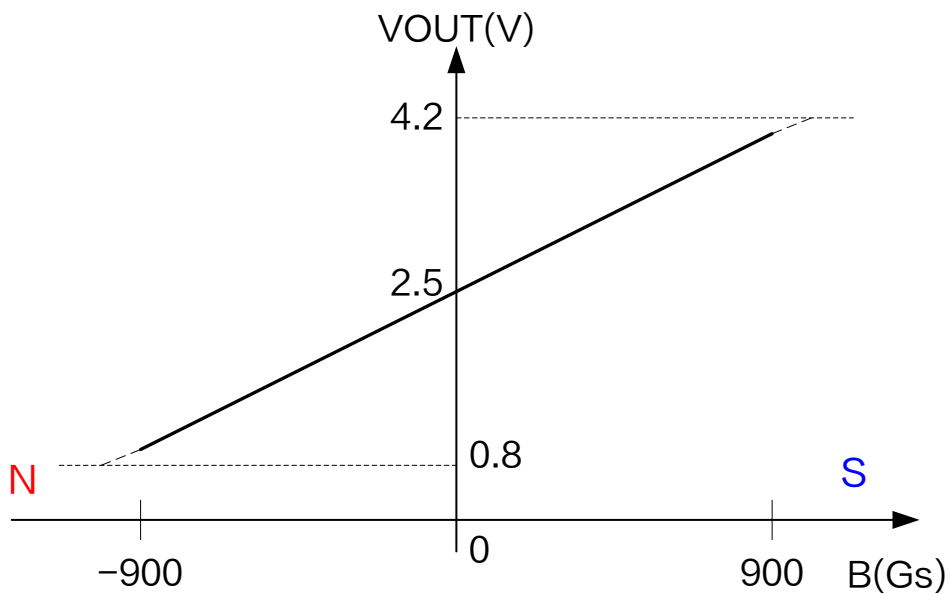
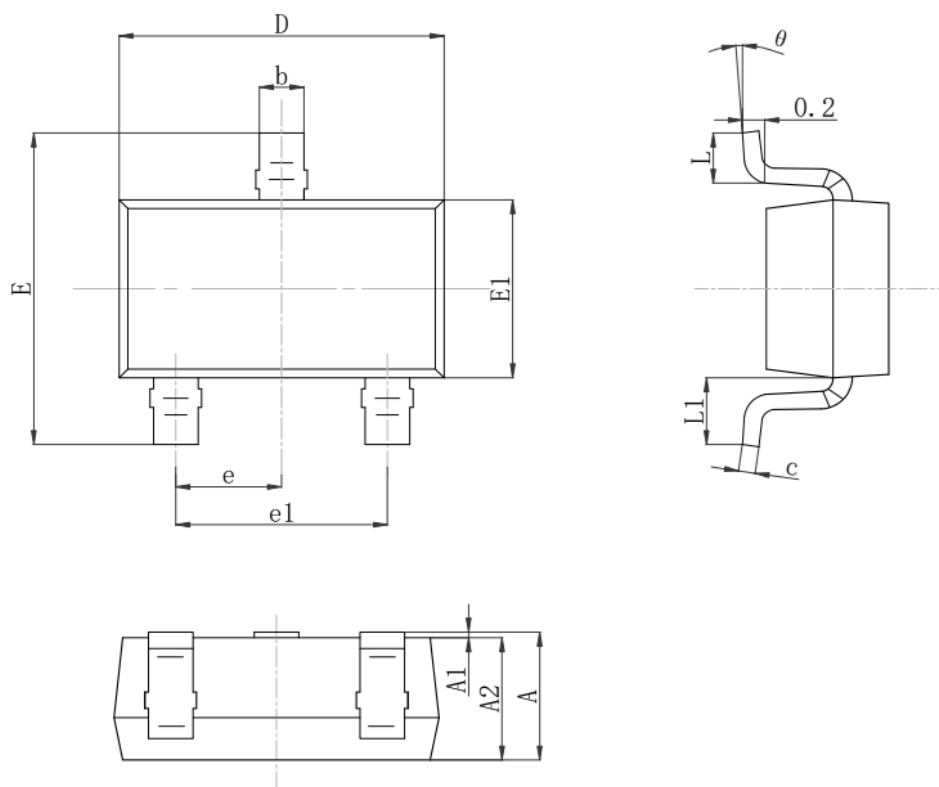

Figure4. XL594 Output characteristic curve

Package Information

SOT23-3



Symbol	Dimensions In Millimeters		Dimensions In Inches	
	Min.	Max.	Min.	Max.
A	1.05	1.25	0.041	0.049
A1	0.00	0.10	0.000	0.004
A2	1.05	1.15	0.041	0.045
b	0.30	0.50	0.012	0.020
c	0.10	0.20	0.004	0.008
D	2.82	3.05	0.111	0.120
E1	1.50	1.70	0.059	0.067
E	2.65	2.95	0.104	0.116
e	0.95 REF.		0.037 REF.	
e1	1.80	2.00	0.071	0.079
L	0.30	0.60	0.012	0.024
L1	0.57	0.63	0.022	0.025
θ	0°	8°	0°	8°

Linear Hall Sensor	XL594
--------------------	-------

Important Notice

XLSEMI reserve the right to make modifications, enhancements, improvements, corrections or other changes without notice at any time. XLSEMI does not assume any liability arising out of the application or use of any product described herein; neither does it convey any license under its patent rights, nor the rights of others. XLSEMI assumes no liability for applications assistance or the design of Buyers' products. Buyers are responsible for their products and applications using XLSEMI components. To minimize the risks associated with Buyers' products and applications, Buyers should provide adequate design and operating safeguards. XLSEMI warrants performance of its products to the specifications applicable at the time of sale, in accordance with the warranty in XLSEMI's terms and conditions of sale of semiconductor products. Testing and other quality control techniques are used to the extent XLSEMI deems necessary to support this warranty. Except where mandated by applicable law, testing of all parameters of each component is not necessarily performed.

For the latest product information, go to www.xlsemi.com.