

Latching Hall Switch Sensor

XL528T

Features

- Wide Operating Voltage Range: 3.3V~90V
- Anti-Surge of Output Terminal: $\geq 90V$
- Reverse Supply Protection
- Device HBM ESD Classification Level Class3B
- Temperature Grade 0: $-40^{\circ}C$ to $150^{\circ}C$
Ambient Operating Temperature Range
- Low Quiescent Current: 1.3mA
- 30mA Load Capacity
- Excellent Magnetic Field Symmetry
- Magnetic Field Operate Point : +110Gs
- Magnetic Field Release Point : -110Gs
- TO92S-3 Package

Applications

- Brushless DC Motors
- Motor and Fan Control System
- Location and Speed Detection

General Description

The XL528T is a high-voltage, wide-temperature-range latching Hall-effect switch sensor optimized for motor applications, supporting a wide supply voltage range from 3.3V to 90V with low operating current. Adopting a collector open circuit output architecture, XL528T provides a load capacity of up to 30mA, widely used in automotive electronics, industrial control and other applications.

The XL528T integrates a reference voltage source, Hall array, differential comparator, hysteresis latch, and power output stage, providing high magnetic field response sensitivity, symmetry, and strong immunity to electromagnetic interference over the full voltage range and full temperature range.

Typical application schematic

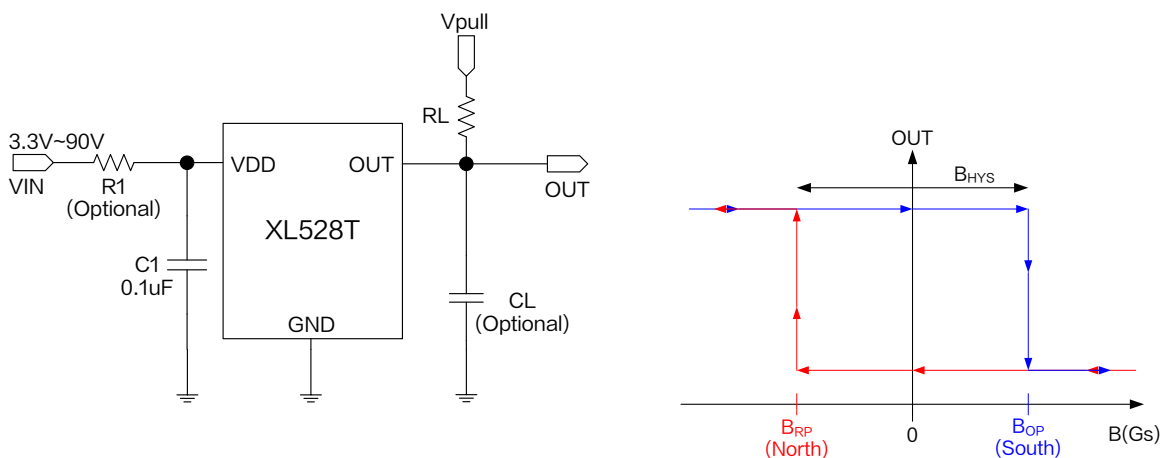

Figure1.XL528T Typical application schematic and output characteristic curve

Latching Hall Switch Sensor

XL528T

Pin Configurations

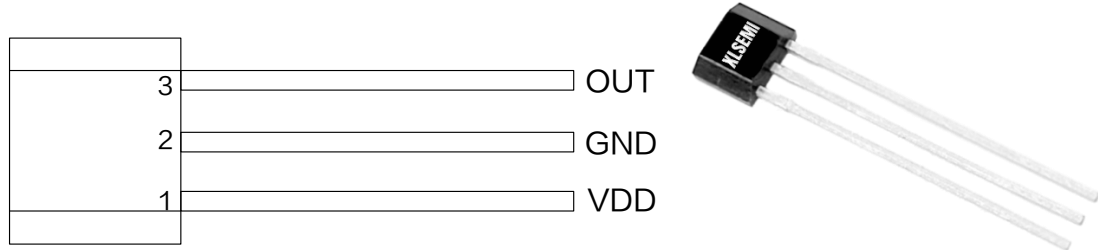

Figure2.Pin Configuration of XL528T

Table 1.Pin Description

Pin Number	Pin Name	Description
1	VDD	Supply Voltage Input Pin. XL528T operates from 3.3V to 90V DC voltage.
2	GND	Ground pin.
3	OUT	Open Collector Output Pin, requires a resistor pull-up.

Ordering Information

Order Information	Marking ID	Package Type	Eco Plan	Packing Type Supplied As
XL528T	XL528	TO92S-3	RoHS & HF	1000 Units Per Bag

Function Block

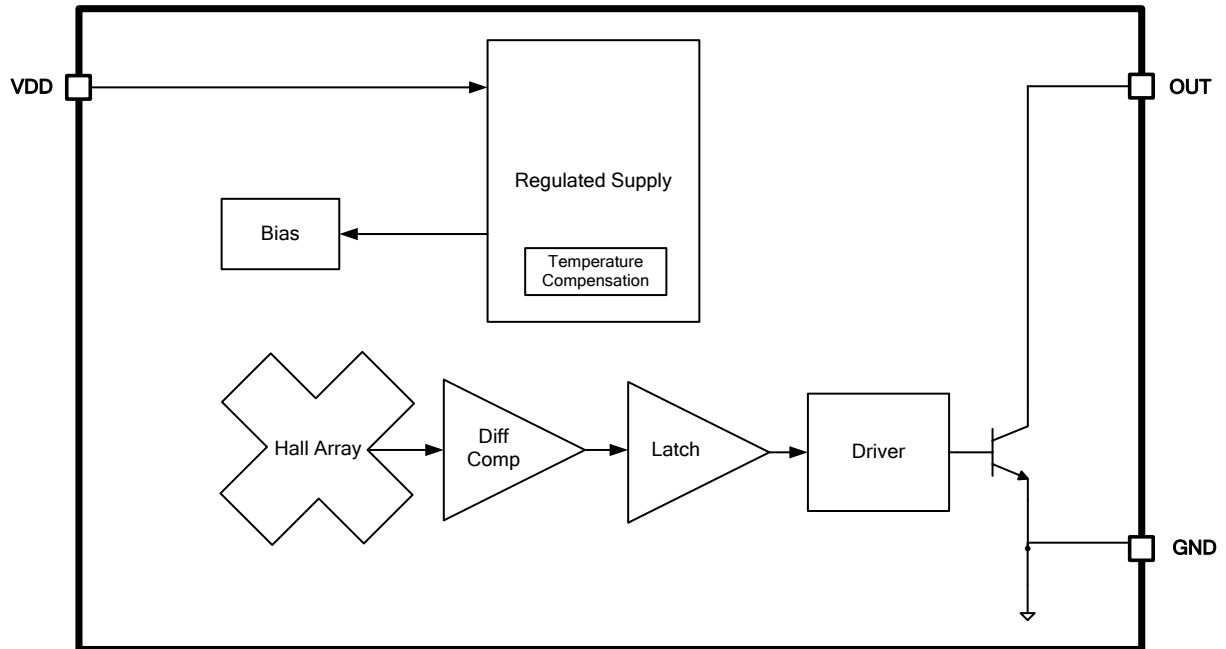

Figure3.Function Block Diagram of XL528T

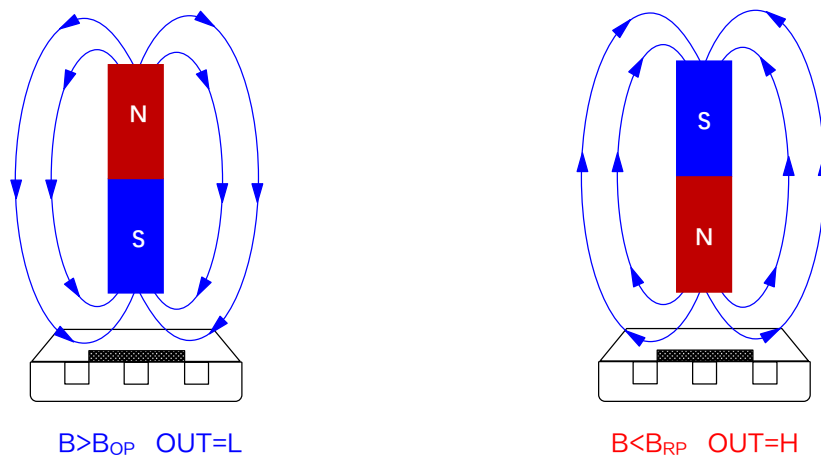

Figure4.Magnetic Field Direction Definition

Latching Hall Switch Sensor

XL528T

Absolute Maximum Ratings (Note1)

Parameter	Symbol	Value	Unit
Input Voltage	V_{DD}	-90 ~ 120	V
Output Pin Voltage	V_{OUT}	-0.5 ~ 90	V
Output Pin Current Sink	I_{SINK}	0 ~ 30	mA
Thermal Resistance (TO92S-3) (Junction to Ambient, No Heatsink, Free Air)	R_{JA}	160	°C/W
Operating Temperature	T_A	-40 ~ 150	°C
Operating Junction Temperature	T_J	-40 ~ 180	°C
Motor Operating Temperature Range	T	-40 ~ 180	°C
Storage Temperature	T_{STG}	-65 ~ 180	°C
Lead Temperature (Soldering, 10 sec)	T_{LEAD}	260	°C
ESD (HBM)	-	≥8000	V
IEC61000-4-2 ESD Contact Discharge (OUT Pin)	-	21	kV
IEC61000-4-2 ESD Air Discharge (OUT Pin)	-	30	kV

Note1: Stresses greater than those listed under Maximum Ratings may cause permanent damage to the device. This is a stress rating only and functional operation of the device at these or any other conditions above those indicated in the operation is not implied. Exposure to absolute maximum rating conditions for extended periods may affect reliability.

Latching Hall Switch Sensor

XL528T

XL528T Electrical Characteristics

$T_A = 25^\circ\text{C}$, $V_{DD} = V_{Pull} = 5\text{V}$, $R_L = 1\text{k}\Omega$, $R_1 = 0\Omega$, system parameters test circuit figure1, unless otherwise specified.

Parameters	Symbol	Test Condition	Min.	Typ.	Max.	Unit
Operation Voltage	V_{DD}	–	3.3	5.0	90	V
Anti-Surge of Input Terminal	V_{DD_Surge}	D=25%, T=20 μs , 10 cycles, B>B _{OP}	125	–	–	V
Anti-Surge of Output Terminal	V_{OUT_Surge}	D=25%, T=20 μs , 10 cycles, B>B _{OP}	90	–	–	V
Reverse Supply Voltage	V_{DDR}	–	-90	–	–	V
Quiescent Current	I_Q	OUT=H	–	1.3	–	mA
Operation Supply Current	I_{DD}	OUT=L	–	2.5	–	mA
Power-on time	t_{ON}	–	–	35	50	μs
Output Saturation Voltage	V_{CE}	$I_{OUT}=30\text{mA}$	–	–	0.5	V
Output Delay Time	t_d	B=B _{RP} to B _{OP}	–	10	25	μs
Output Rise Time	t_r	CL=50pF	–	–	0.5	μs
Output Fall Time	t_f	CL=50pF	–	–	0.2	μs

XL528T Magnetic Characteristics (Note2)

$T_A = 25^\circ\text{C}$, $V_{DD} = V_{Pull} = 5\text{V}$, $R_L = 1\text{k}\Omega$, $R_1 = 0\Omega$, system parameters test circuit figure1, unless otherwise specified.

Parameters	Symbol	Test Condition	Min.	Typ.	Max.	Unit
Bandwidth	f_{BW}	–	–	–	100	kHz
Magnetic Field Operate Point	B _{OP}	–	+70	+110	+150	Gs
Magnetic Field Release Point	B _{RP}	–	-150	-110	-70	Gs
Magnetic Hysteresis	B _{HYS}	–	–	220	–	Gs
Magnetic Offset	B _O	$B_O = (B_{OP} + B_{RP})/2$	-40	0	+40	Gs

Note2: 1mT=10Gs; A south pole near the marked side of the package is a positive magnetic field; Powering-on the device in the hysteresis region allows an indeterminate output state. The correct state is attained after the first excursion beyond B_{OP} or B_{RP}.

Typical Characteristics (Note3)

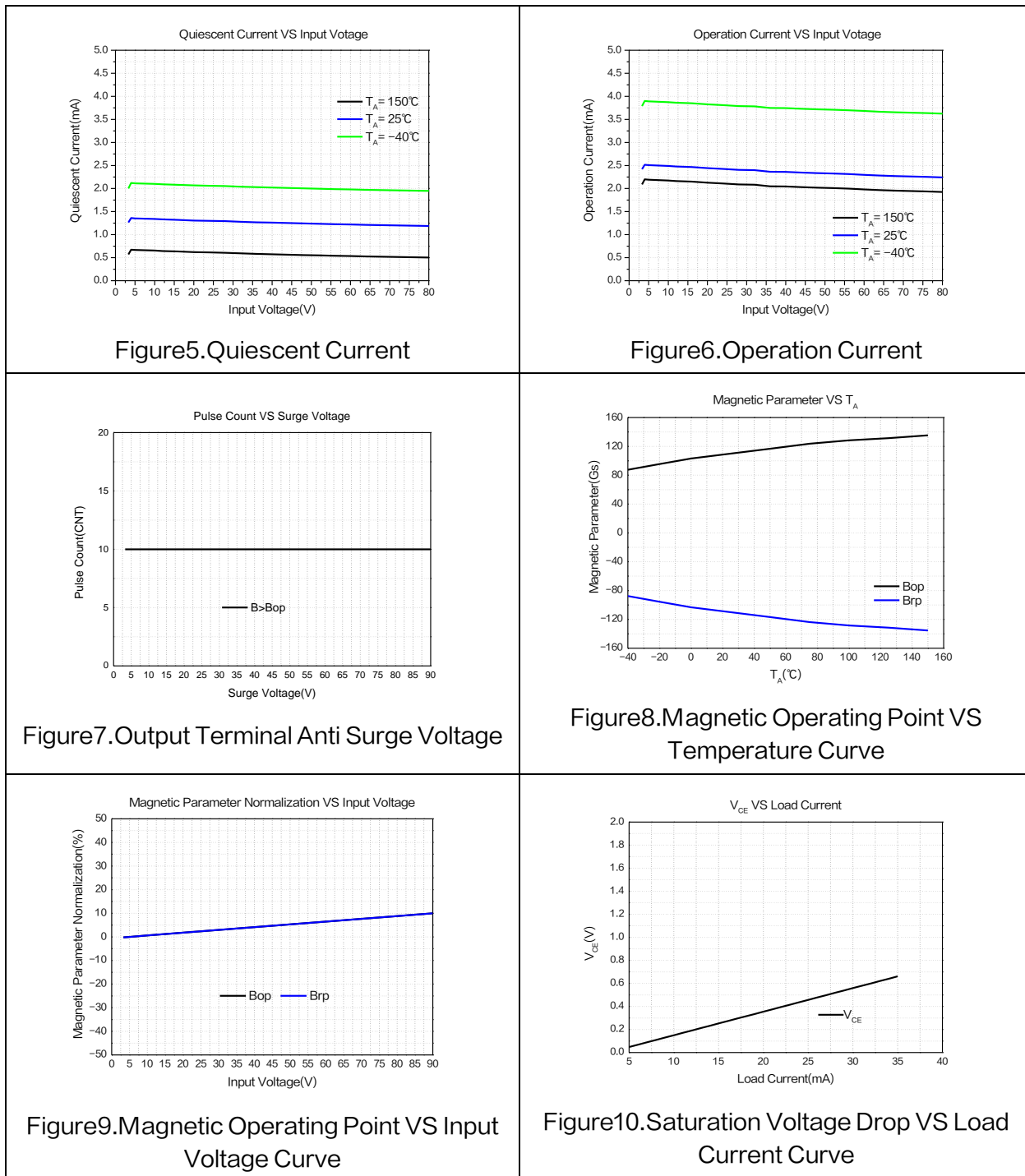

Note3: The Surge voltage in Figure 7 is a square wave with a high-level width of 5 μs and a period of 20 μs . This square wave consists of 10 cycles.

Latching Hall Switch Sensor

XL528T

Package Information

TO92S-3

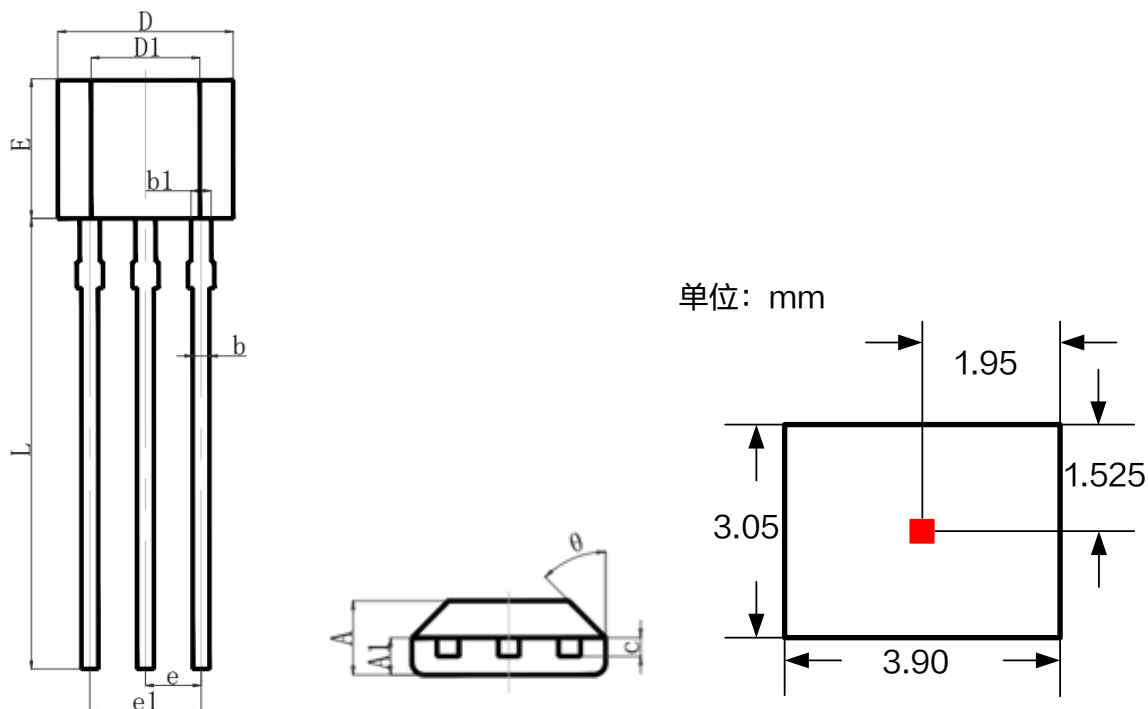

Symbol	Dimensions In Millimeters		Dimensions In Inches	
	Min.	Max.	Min.	Max.
A	1.42	1.62	0.056	0.064
A1	0.66	0.87	0.026	0.034
b	0.33	0.56	0.013	0.022
b1	0.40	0.51	0.016	0.020
c	0.33	0.51	0.013	0.020
D	3.90	4.10	0.154	0.161
D1	2.28	2.68	0.090	0.106
E	2.90	3.25	0.114	0.128
e	1.27 REF		0.050 REF	
e1	2.44	2.64	0.096	0.104
L	13.50	15.50	0.531	0.610
θ	45° REF		45° REF	

Latching Hall Switch Sensor	XL528T
-----------------------------	--------

Important Notice

XLSEMI reserve the right to make modifications, enhancements, improvements, corrections or other changes without notice at any time. XLSEMI does not assume any liability arising out of the application or use of any product described herein; neither does it convey any license under its patent rights, nor the rights of others. XLSEMI assumes no liability for applications assistance or the design of Buyers' products. Buyers are responsible for their products and applications using XLSEMI components. To minimize the risks associated with Buyers' products and applications, Buyers should provide adequate design and operating safeguards. XLSEMI warrants performance of its products to the specifications applicable at the time of sale, in accordance with the warranty in XLSEMI's terms and conditions of sale of semiconductor products. Testing and other quality control techniques are used to the extent XLSEMI deems necessary to support this warranty. Except where mandated by applicable law, testing of all parameters of each component is not necessarily performed.

For the latest product information, go to www.xlsemi.com.