

Features

- Specially optimized for unipolar applications of magnetic axis keyboards
- Widelinear range:0.8V~2.18V@V_{DD}=3.3V
- Low Operation Current: 1.2mA
- Wide Operating Voltage Range: 2.7V~6V
- Zero-point (No magnetic field) output voltage: 2.18V@V_{DD}=3.3V
- Sensitivity: 2.28mV/Gs@V_{DD}=3.3V
- Linearity: ±1%
- Low noise output without external capacitor filtering
- Temperature Grade 2: -40°C to 105°C Ambient Operating Temperature Range
- Device HBM ESD Classification Level Class3A
- TSOT23-3 package

Applications

- Magnetic Axis Keyboards

General Description

The XL41N is a linear Hall-effect sensor specifically engineered for magnetic axis keyboards, featuring low power consumption, wide operating voltage, and extended temperature range, with an output voltage varies proportionally with the strength of the induced magnetic field, and its linear output voltage range follows the variation of the power supply voltage. The XL41N's typical operating voltage is 3.3V, the default zero-point output voltage (without magnetic field) at V_{DD}=3.3V is 2.18V, with low operation current, the operating temperature range supports -40°C~105°C.

The XL41N integrates high precision current source, temperature compensation module, Hall array, amplifier, driver module and other circuit modules, which provides high linearity and strong immunity to electromagnetic interference over the full voltage range and full temperature range.

Typical application schematic

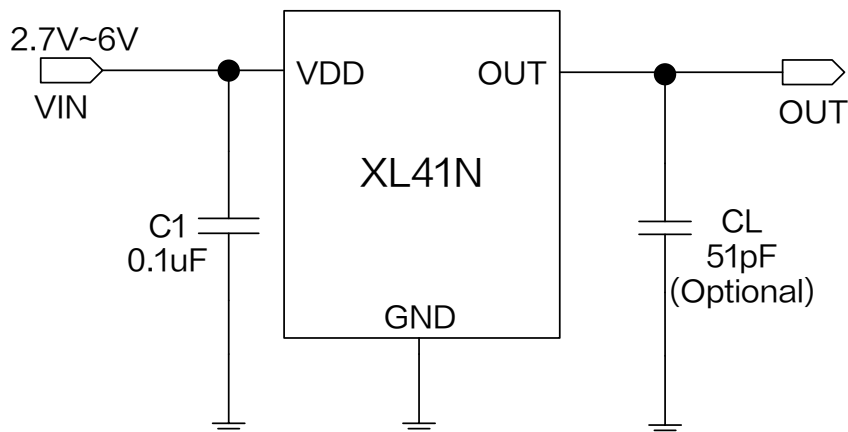

Figure1.XL41N Typical application schematic

Low Power Linear Hall Sensor

XL41N

Pin Configurations

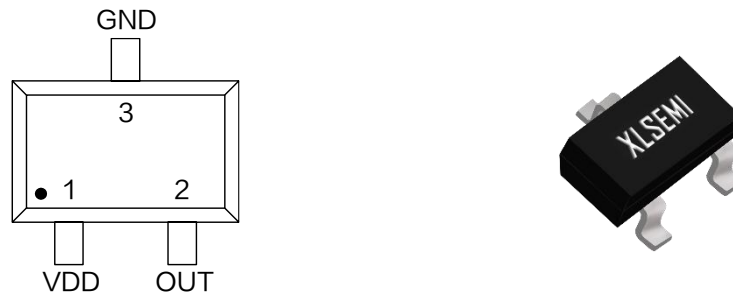

Figure2.Pin Configuration of XL41N

Table 1.Pin Description

Pin Number	Pin Name	Description
1	VDD	Supply Voltage Input Pin. XL41N operates from 2.7V to 6V DC voltage.
2	OUT	Output Pin.
3	GND	Ground pin.

Ordering Information

Order Information	Marking ID	Package Type	Eco Plan	Packing Type Supplied As
XL41N	XL41N	TSOT23-3	RoHS & HF	3000 Units Per Reel

Function Block

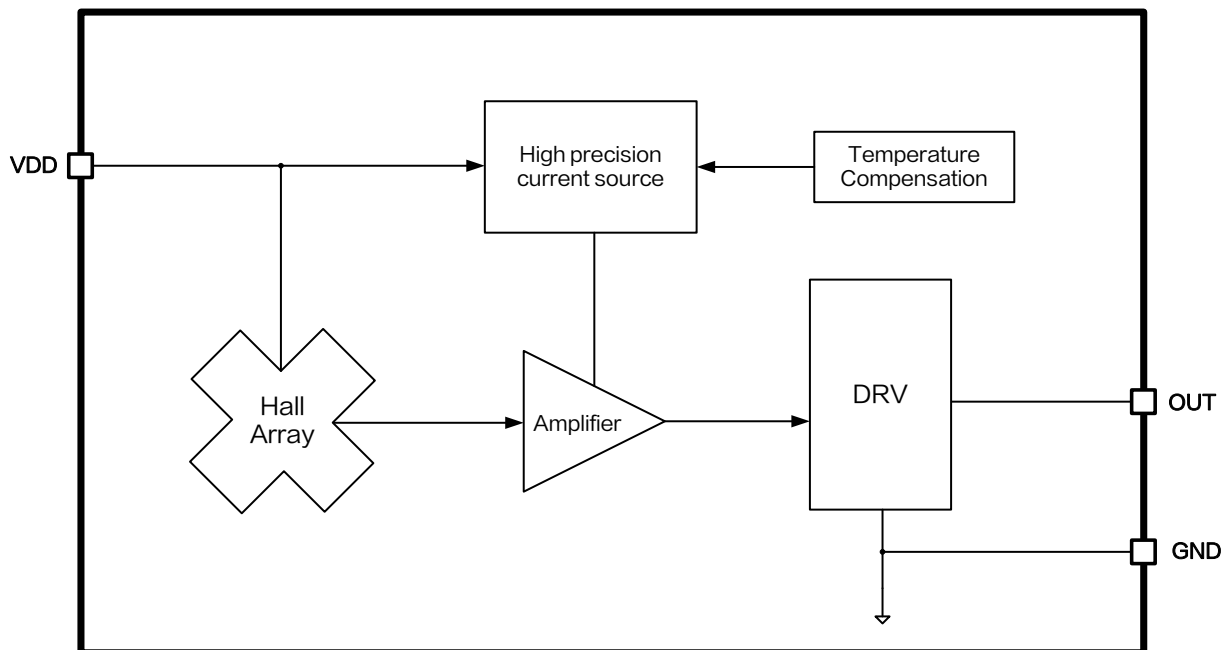

Figure3.Function Block Diagram of XL41N

Absolute Maximum Ratings (Note 1)

Parameter	Symbol	Value	Unit
Input Pin Voltage	V_{DD}	-0.3 ~ 10	V
Output Pin Voltage	V_{OUT}	-0.3 ~ 10	V
Thermal Resistance (TSOT23-3) (Junction to Ambient, No Heatsink, Free Air)	R_{JA}	200	°C/W
Operating Temperature	T_A	-40 ~ 105	°C
Operating Junction Temperature	T_J	-40 ~ 125	°C
Storage Temperature	T_{STG}	-65 ~ 150	°C
Lead Temperature (Soldering, 10 sec)	T_{LEAD}	260	°C
ESD (HBM)	-	≥5000	V

Note 1: Stresses greater than those listed under Maximum Ratings may cause permanent damage to the device. This is a stress rating only and functional operation of the device at these or any other conditions above those indicated in the operation is not implied. Exposure to absolute maximum rating conditions for extended periods may affect reliability.

XL41N Electrical Characteristics (Note 2)

$T_A = 25^\circ\text{C}$, $V_{DD} = 3.3\text{V}$, system parameters test circuit figure1, unless otherwise specified.

Parameters	Symbol	Test Condition	Min.	Typ.	Max.	Unit
Operation Voltage	V_{DD}	–	2.7	3.3	6	V
Operation Current	I_{DD}	–	0.5	1.2	1.6	mA
Output Load Resistance	R_L	$B = -1000\text{Gs}$	20	–	–	$k\Omega$
Output Voltage Range	$V_{OUT(H)}$	$B = +1000\text{Gs}$ $V_{DD} = 3.3\text{V}$	2.45	2.5	–	V
		$B = +1000\text{Gs}$ $V_{DD} = 5.0\text{V}$	4.15	4.2	–	V
	$V_{OUT(L)}$	$B = -1000\text{Gs}$ $V_{DD} = 3.3\text{V}$	–	0.8	0.85	V
		$B = -1000\text{Gs}$ $V_{DD} = 5.0\text{V}$	–	0.8	0.85	V
Static Output Voltage	$V_{OUT(Q)}$	$B = 0\text{Gs}$ $V_{DD} = 3.3\text{V}$	2.006	2.18	2.354	V
		$B = 0\text{Gs}$ $V_{DD} = 5.0\text{V}$	–	3.30	–	V
Linearity	Lin	–	–1	–	1	%
Output Settling Time	–	$B = 0\text{Gs}$	–	2	–	μs
Output Noise	–	Bandwidth= 10Hz to 10kHz	–	2	–	mV

Note 2:

- (1) Linearity is the degree to which the static characteristic curve between the input and output quantities deviates from a straight line.
- (2) The output settling time is the time interval from when the output voltage begins to establish until it stabilizes at 90% of the steady-state output voltage.

Low Power Linear Hall Sensor

XL41N

XL41N Magnetic Characteristics (Note 3)

Parameters	Symbol	Test Condition	Min.	Typ.	Max.	Unit
Sensitivity	Sens	$V_{DD}=3.3V$	2.095	2.28	2.465	mV/Gs
		$V_{DD}=5.0V$	-	5.35	-	mV/Gs

Note 3:

(1) The magnetic South Pole (S) is defined as the positive magnetic field. The sensitivity in the table corresponds to measurements taken with the magnetic field perpendicular to the back side of the chip's marking surface.

(2) XL41N is optimized for unipolar applications of magnetic axis keyboards. When $V_{DD}=3.3V$, the sensitivity corresponding to output voltage is in the linear range of 0.8V~2.18V as shown in the table. When $V_{DD}=5.0V$, the sensitivity corresponding to output voltage is in the linear range of 0.8V~3.30V as shown in the table.

Output Characteristics

$T_A = 25^\circ\text{C}$, system parameters test circuit figure1, unless otherwise specified.

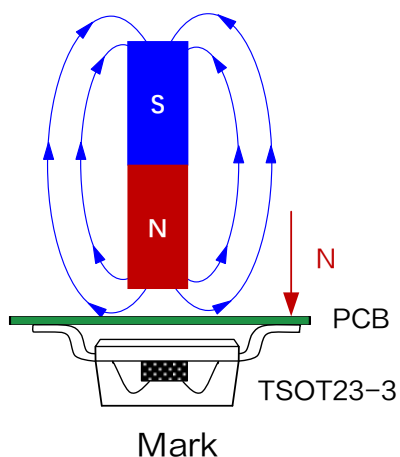

Figure4.Application diagram of XL41N

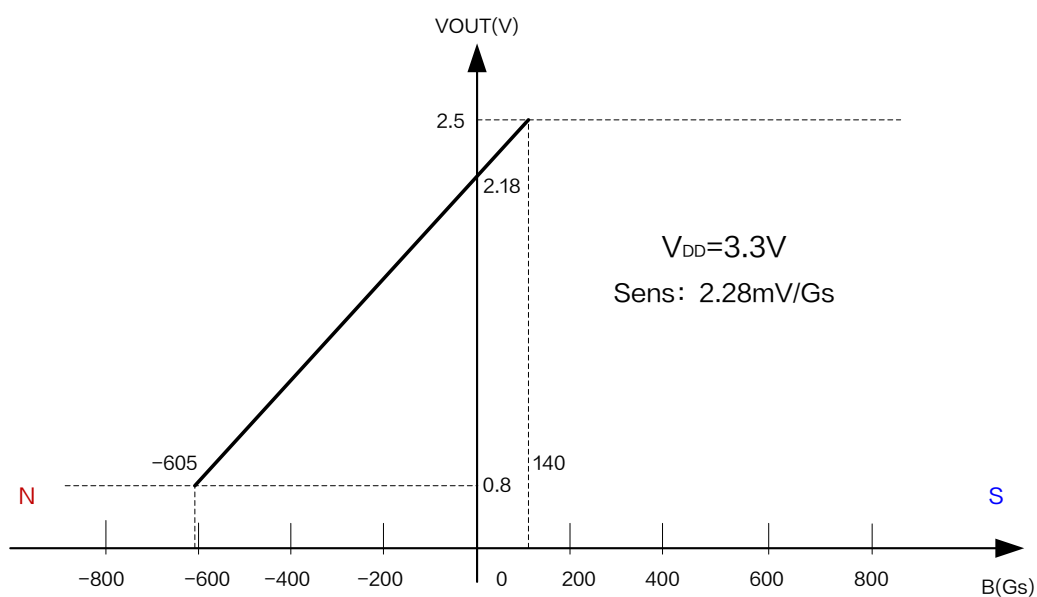

Figure5.XL41N Output characteristic curve ($V_{DD} = 3.3\text{V}$)

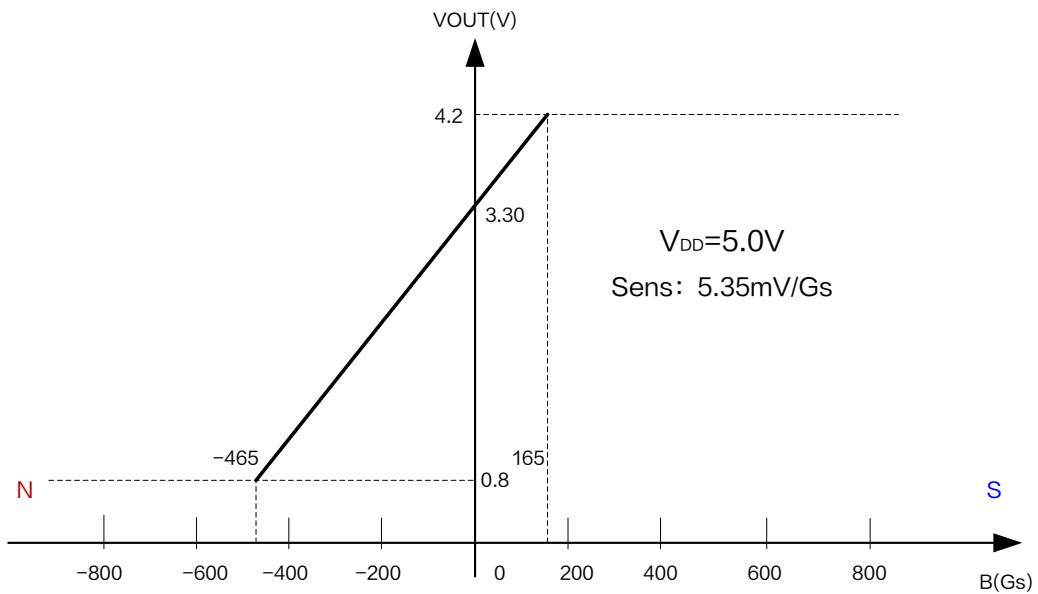

Figure6.XL41N Output characteristic curve ($V_{DD} = 5.0V$)

Note 4: At room temperature, when $V_{DD}=3.3V$, the linear range of chip unipolar is 0.8V~2.18V; When $V_{DD}=5.0V$, the linear range of unipolar polarity of the chip is 0.8V~3.30V.

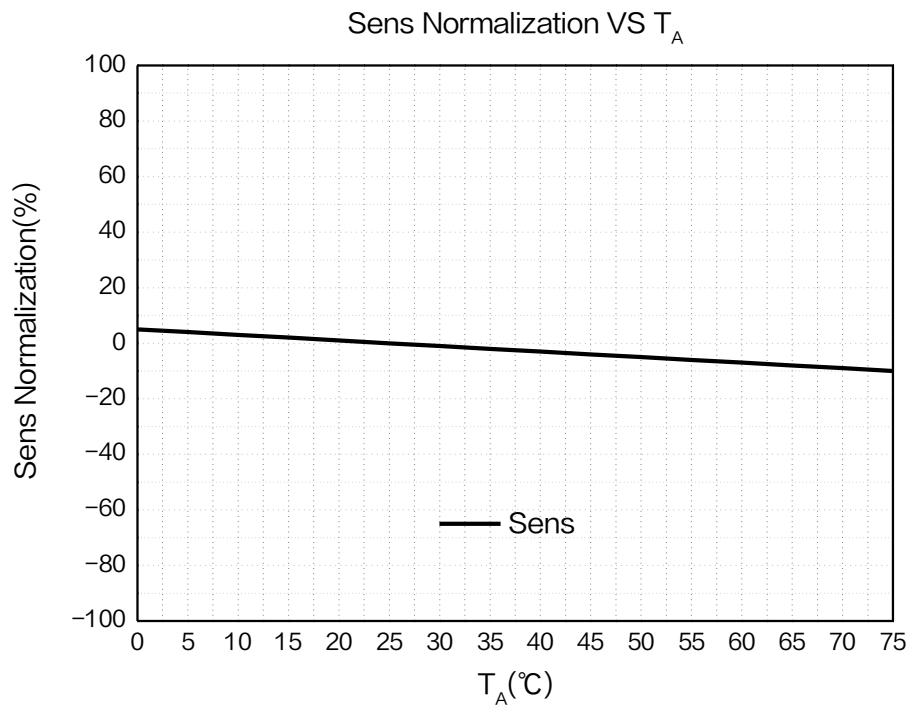
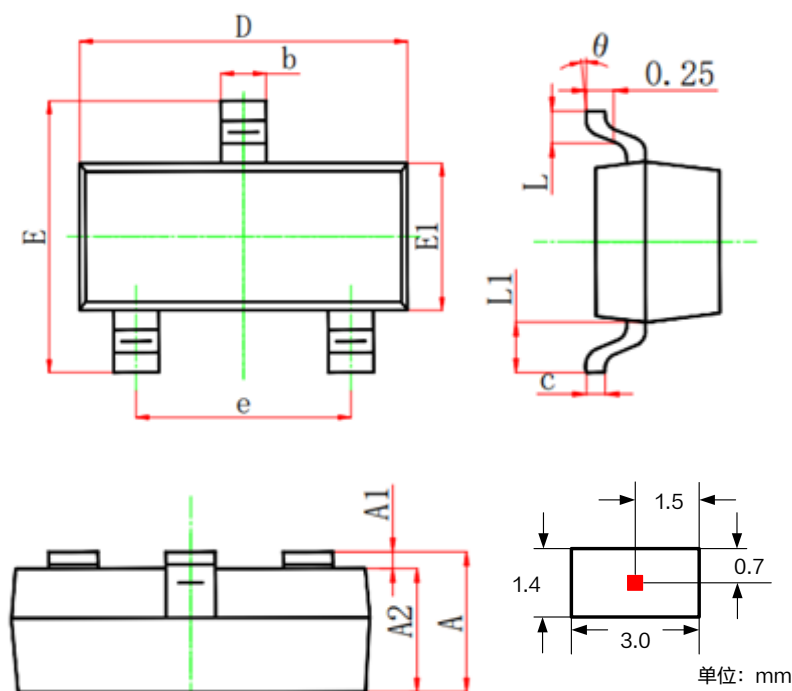

Figure7. Sensitivity versus temperature curve of XL41N ($V_{DD} = 3.3V$)

Package Information

TSOT23-3



Symbol	Dimensions In Millimeters		Dimensions In Inches	
	Min.	Max.	Min.	Max.
A	1.15 Max		0.045 Max	
A1	0.000	0.100	0.000	0.004
A2	0.900	1.100	0.035	0.043
b	0.300	0.500	0.012	0.020
c	0.132	0.202	0.005	0.008
D	2.800	3.000	0.110	0.118
E	2.250	2.550	0.089	0.100
E1	1.200	1.400	0.047	0.055
e	1.800	2.000	0.071	0.079
L	0.300	0.500	0.012	0.020
L1	0.550 REF		0.022 REF	
θ	0°	8°	0°	8°

Low Power Linear Hall Sensor	XL41N
------------------------------	-------

Important Notice

XLSEMI reserve the right to make modifications, enhancements, improvements, corrections or other changes without notice at any time. XLSEMI does not assume any liability arising out of the application or use of any product described herein; neither does it convey any license under its patent rights, nor the rights of others. XLSEMI assumes no liability for applications assistance or the design of Buyers' products. Buyers are responsible for their products and applications using XLSEMI components. To minimize the risks associated with Buyers' products and applications, Buyers should provide adequate design and operating safeguards. XLSEMI warrants performance of its products to the specifications applicable at the time of sale, in accordance with the warranty in XLSEMI's terms and conditions of sale of semiconductor products. Testing and other quality control techniques are used to the extent XLSEMI deems necessary to support this warranty. Except where mandated by applicable law, testing of all parameters of each component is not necessarily performed.

For the latest product information, go to www.xlsemi.com.