

Features

- Can be driven by a single 5V power supply
- Built in Current Limit Function
- Easy circuit design
- Few external components
- High reliability
- Available in SOP16/DIP16 package

Applications

- Telephony equipment
- Security equipment
- Audio and video devices
- Air-conditioning equipment
- Wide rang of other equipment and devices

General Description

The XL1192 conforms to the HBS(Home Bus) specification, and has functions for the reception and transmission of data. AMI is adopted for the waveforms of signals handled by the transmission and reception units, designed for connection to twisted-pair lines.

The IC can be driven by a single 5V power supply, and incorporates an output transistor to reduce the number of external components required.

Telephone equipment, security equipment, audio or video equipment, air-conditioning equipment, and a wide range of other devices can be connected to a bus line to enable mutual communications.

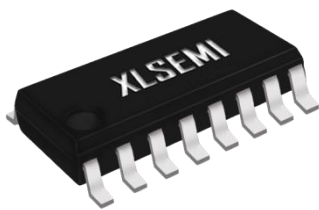
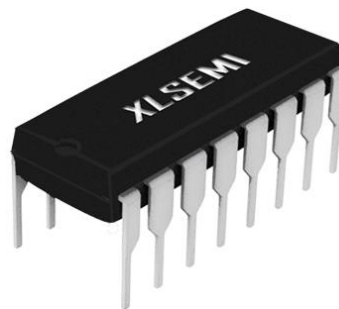
**SOP16****DIP16****Figure1. Package Type of XL1192**

Pin Configurations

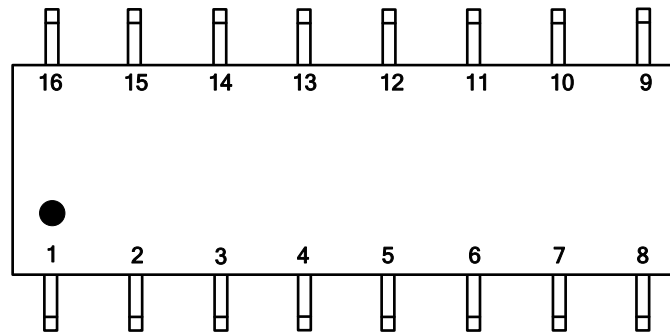

Figure2. Pin Configuration of XL1192 (Top View)

Table 1 Pin Description

Pin Number	Pin Name	Pin Number	Pin Name
1	DATA OUT	9	OUT(A)
2	VIN	10	OUT(B)
3	Boost capacitor pin	11	VCC
4	Boost capacitor pin	12	COLLECTOR(b)
5	RESET	13	GND
6	DATA IN	14	COLLECTOR(a)
7	DRIVER(B)	15	IN(2)
8	DRIVER(A)	16	IN(1)

Function Block

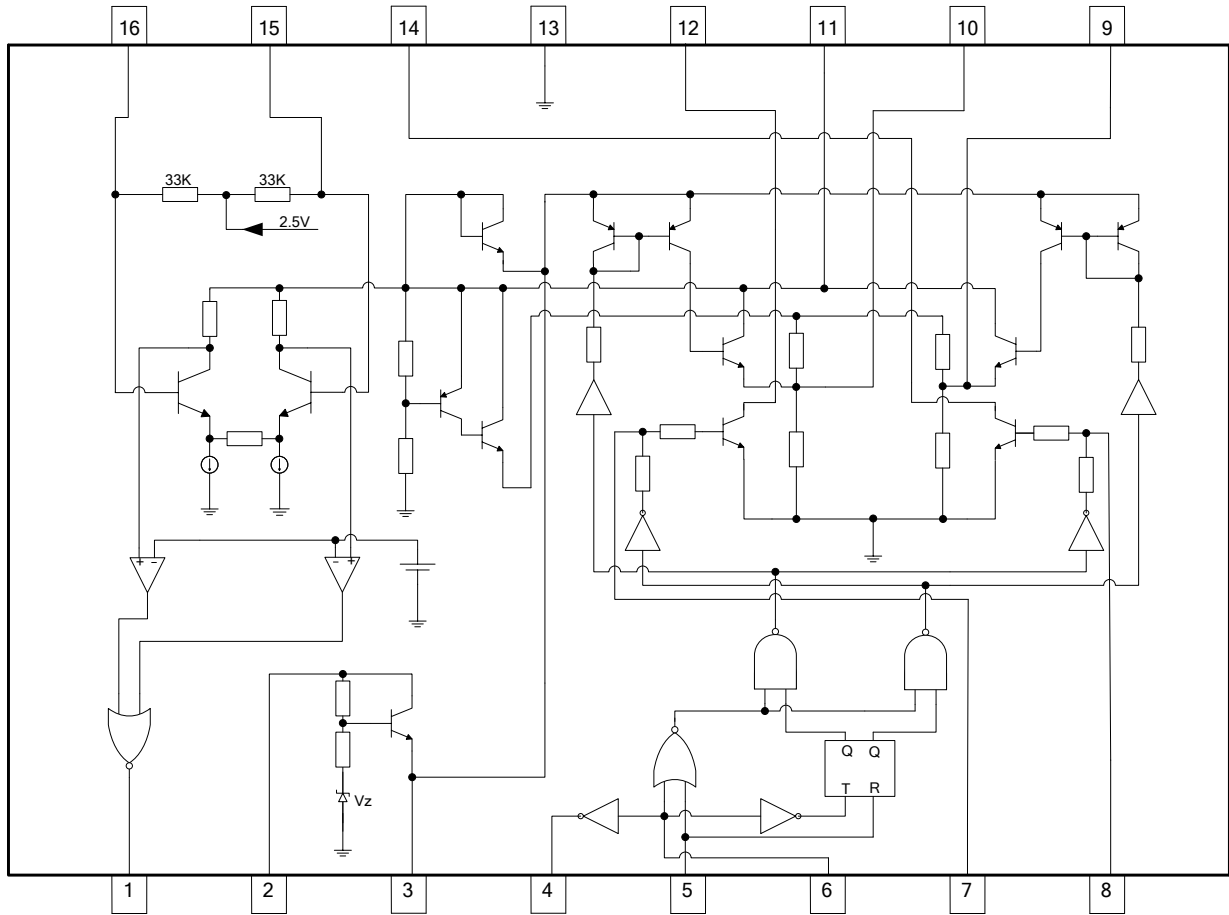

Figure3. Function Block Diagram of XL1192

Typical Application Circuit

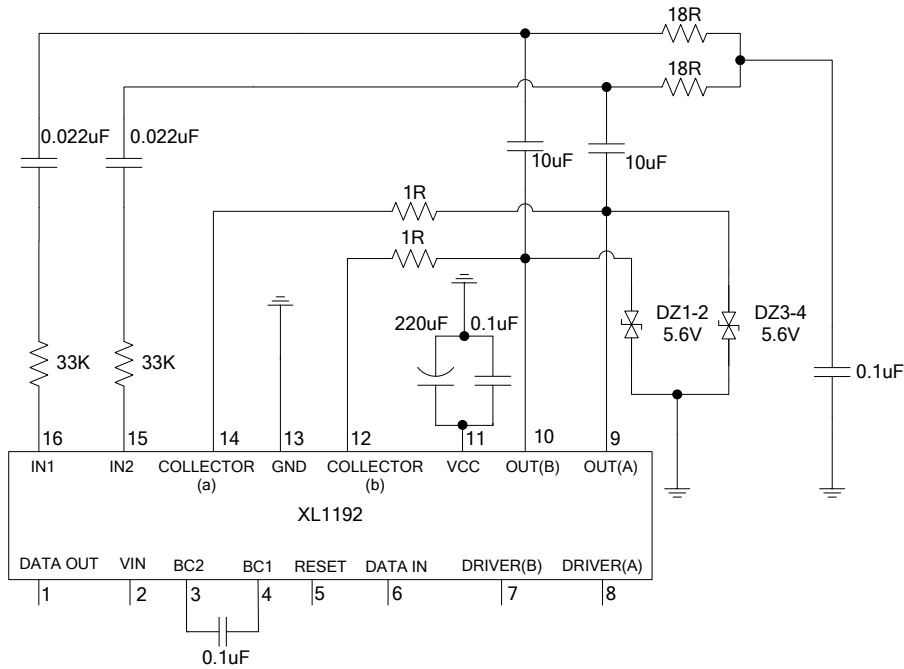
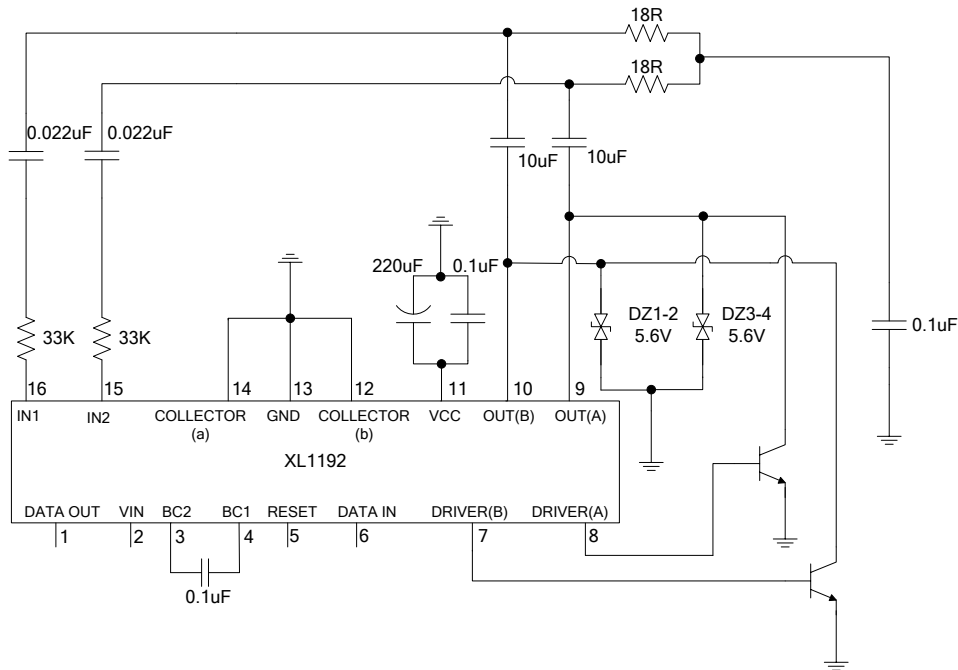

Figure4. XL1192 Typical Application Circuit (No external transistor)



The external transistor can increase the drive

Figure5. XL1192 Typical Application Circuit (With external transistor)

HBS-Compatible Driver and Receiver Monolithic IC

XL1192

Ordering Information

Order Information	Marking ID	Package Type	Packing Type Supplied As
XL1192S	XL1192S	SOP16	2500 Units on Tape & Reel
XL1192D	XL1192D	DIP16	25 Units Per Tube/ 1000 Units Per Box

Absolute Maximum Ratings (Ta=25°C)

Parameter	Symbol	Value	Unit
Bias voltage range (VIN)	V_{INOP}	8 to 40	V
Power supply voltage (VCC)	$V_{CCmax.}$	-0.3 to 7	V
Operating power supply voltage (VCC)	V_{CCOP1}	4.5to 5.5	V
Recommended power supply voltage range	V_{CCOP2}	4.75 to 5.25	V
Power Dissipation	P_D	450	mW
Operating Junction Temperature	T_J	-40 to 125	°C
Storage Temperature	T_{STG}	-40 to 125	°C
Lead Temperature (Soldering, 10 sec)	T_{LEAD}	260	°C
ESD (HBM)		>2500	V

Note1: Stresses greater than those listed under Maximum Ratings may cause permanent damage to the device. This is a stress rating only and functional operation of the device at these or any other conditions above those indicated in the operation is not implied. Exposure to absolute maximum rating conditions for extended periods may affect reliability.

XL1192 Electrical Characteristics

$V_{CC}=5V$, $GND=0V$, $T_a=25^{\circ}C$; $F_{transmit}=10KHz$ (DUTY=50%), $R_L=36\Omega$ (unless otherwise specified).

Parameters	Symbol	Test Condition	Min.	Typ.	Max.	Unit
Power supply current 1	ICCO	No signal(PIN5= " H ")		12		mA
Power supply current 2	ICCON	In transmission FL=10KHz, $R_L=36\Omega$		68		mA
Transmission output voltage	V_{TO}	Both pins 9 and 10	3.8	4.2	4.6	V_{P-P}
Transmission waveform symmetry	V_{TR}	V_{TO1}/V_{TO2}	0.75	1.0	1.25	
Reception Sensitivity	V_{RS}		0.65	0.75	0.85	V_{P-P}
Noise resistance	V_{RN}	Level at which no errors are output	0.55			V_{P-P}
Input impedance	R_{IN}	Both pins 15 and 16	25	36	46	K Ω
Transmission delay time 1	T_{d1}	cf. transmit/receive waveform diagrams		0.4		μS
Transmission delay time 2	T_{d2}	cf. transmit/receive waveform diagrams		0.5		μS
Transmission delay time 3	T_{d3}	cf. transmit/receive waveform diagrams		1.0		μS
Transmission delay time 4	T_{d4}	cf. transmit/receive waveform diagrams		1.2		μS
Reception output H voltage	V_{ROH}		4.5			V
Reception output L voltage	V_{ROL}				0.5	V
Transmission waveform LOSS1	V_{TLS1}	$V_T=5V$ applied, power on	4.5			V
Transmission waveform LOSS2	V_{TLS2}	$V_T=5V$ applied, power off	4.5			V
H level input voltage	V_{LIH}		2.4			V
L level input voltage	V_{LIL}				0.6	V
H level input current	I_{LIH}	$V_{DATA IN}=2.4V$			10	μA
L level input current	I_{LIL}	$V_{DATA IN}=0.4V$			-300	μA
Bootstrap output H voltage	V_{BR}		7.5	8.0		V

Measuring Circuit

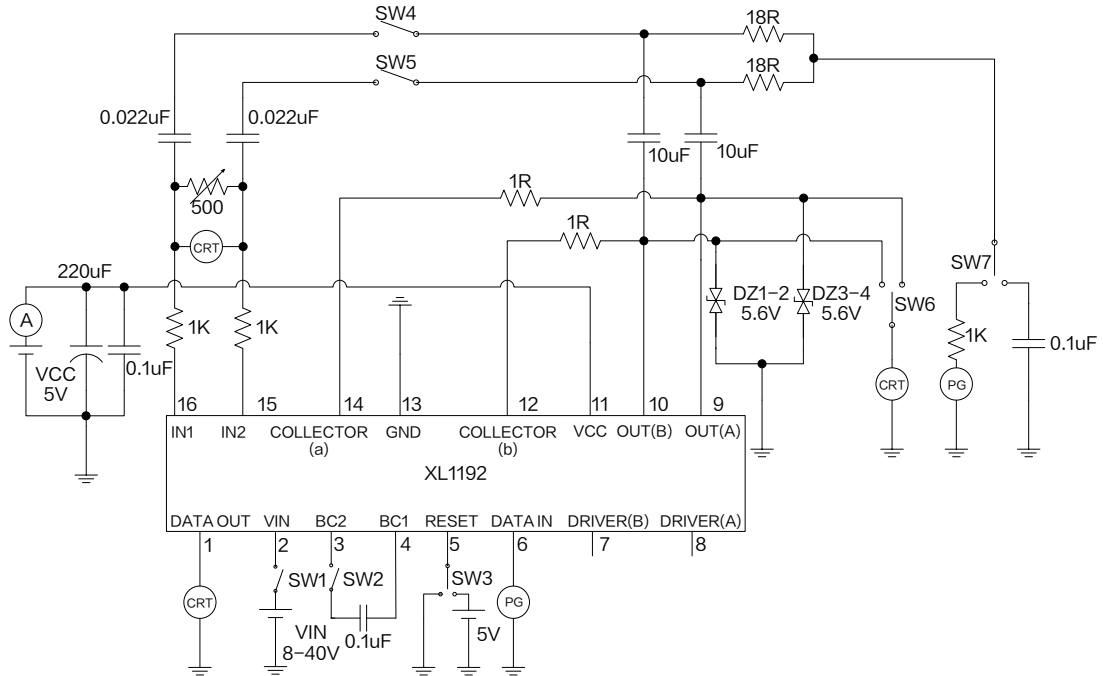

Figure6. XL1192 Measuring Circuit (No external transistor)

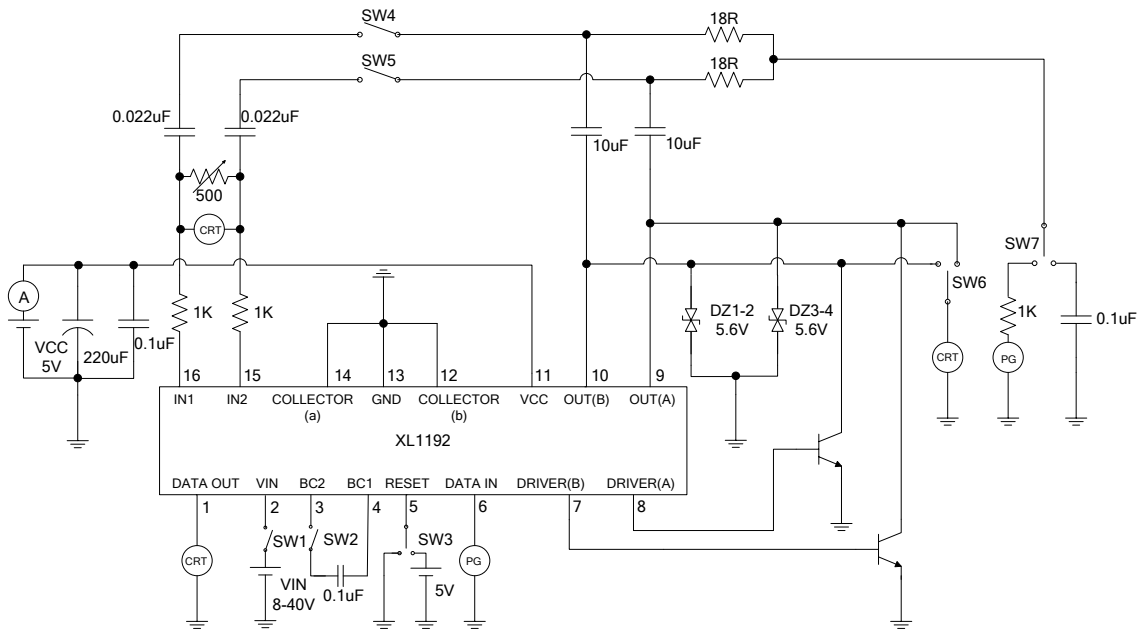
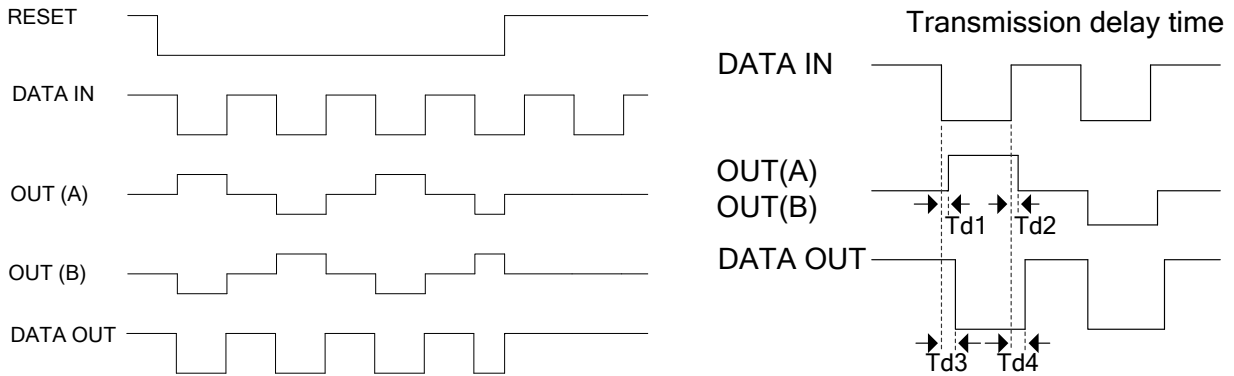

Figure7. XL1192 Measuring Circuit (With external transistor)

HBS-Compatible Driver and Receiver Monolithic IC	XL1192
--	--------

Timing Chart



Note 1: The peripheral components in the block diagram are the constants for F transmit=10kHz. If the frequency is low, larger values should be chosen for the coupling capacitors between the receive and transmit pins and the bus line and for the capacitor connecting pins 3 and 4.

Note 2: A block diagram is shown for an example application in which an external transistor is used; but depending on system conditions the internal transistor may be used, and no external transistor is needed. In such cases pins 7 and 8 are left open, a 1Ω resistance is inserted between pins 10 and 12, and a 1Ω resistance is inserted between pins 9 and 14. When the load resistance (36Ω) is to be varied during use, these resistances (1Ω) should be changed according to the load resistance. If these resistances are omitted, oscillation may occur at low volume levels.

Note 3: When a negative voltage is applied to pins 9 and 10, there should be no abnormal operation of internal circuits between 0 and 6V. However, if a negative voltage exceeding -6V is applied, thyristor operation may result, so it is recommended that an external clamping diode be added.

In addition, no measures have been taken for a negative voltage at pins 12 and 14. Hence if a negative voltage is applied to pins 12 and 14, the internal transistor should not be used.

Note 4: The current limit function is built into this IC. There is a possibility that IC generates heat when the output terminal is short. However, The characteristic changes depending on the substrate condition. Please evaluate IC in the set.

Note 5: The ceramic capacitor should be placed closer the VCC and GND pins to eliminate noise . Increase the grounding vias to decrease the Parasitic parameter.

Package Information

(1)SOP16

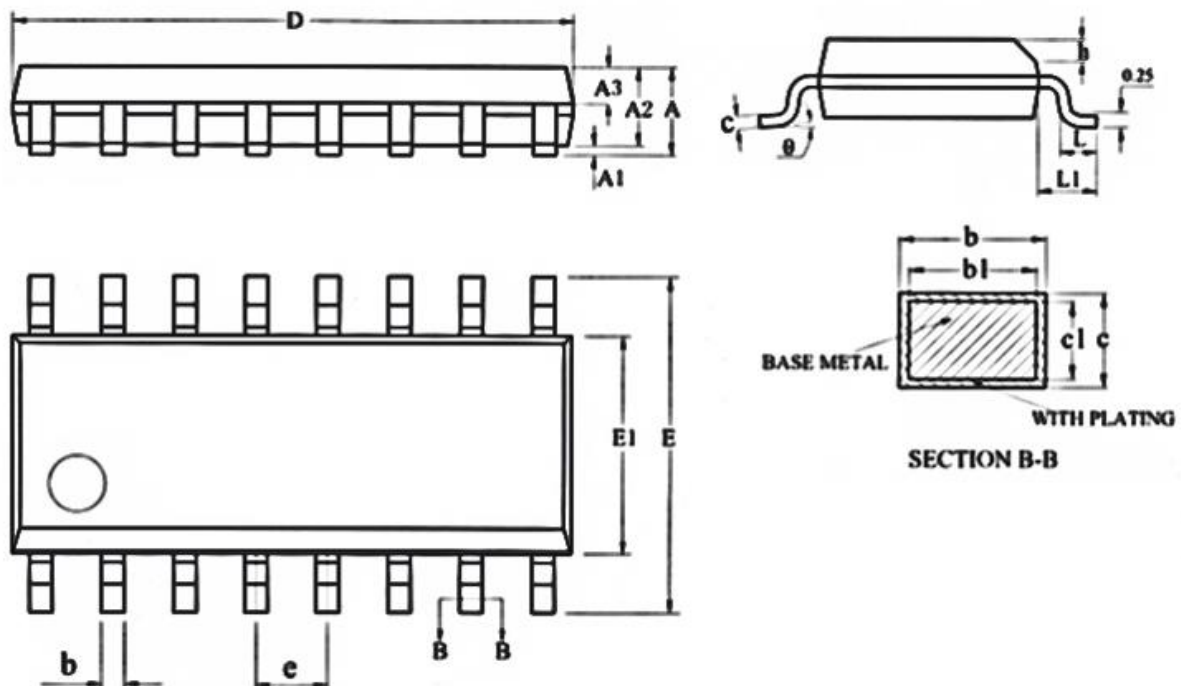

Symbol	Dimensions In Millimeters			Dimensions In Inches		
	Min.	Nom.	Max.	Min.	Nom.	Max.
A	-	-	1.75	-	-	0.069
A1	0.10	0.15	0.25	0.004	0.006	0.010
A2	1.30	1.40	1.50	0.051	0.055	0.059
A3	0.55	0.65	0.75	0.022	0.026	0.030
b	0.33	-	0.51	0.013	-	0.020
b1	0.35	0.40	0.45	0.014	0.016	0.018
c	0.17	-	0.25	0.007	-	0.010
c1	0.19	0.20	0.21	0.007	0.008	0.009
D	9.80	10.00	10.20	0.386	0.393	0.402
E	5.80	6.00	6.20	0.228	0.236	0.244
E1	3.80	3.90	4.00	0.150	0.154	0.157
e	1.27 REF.			0.050 REF.		
h	0.25	-	0.50	0.010	-	0.020
L	0.40	-	1.27	0.015	-	0.050
L1	1.05 REF.			0.041 REF.		
θ	0°	-	8°	0°	-	8°

Package Information

(2)DIP16

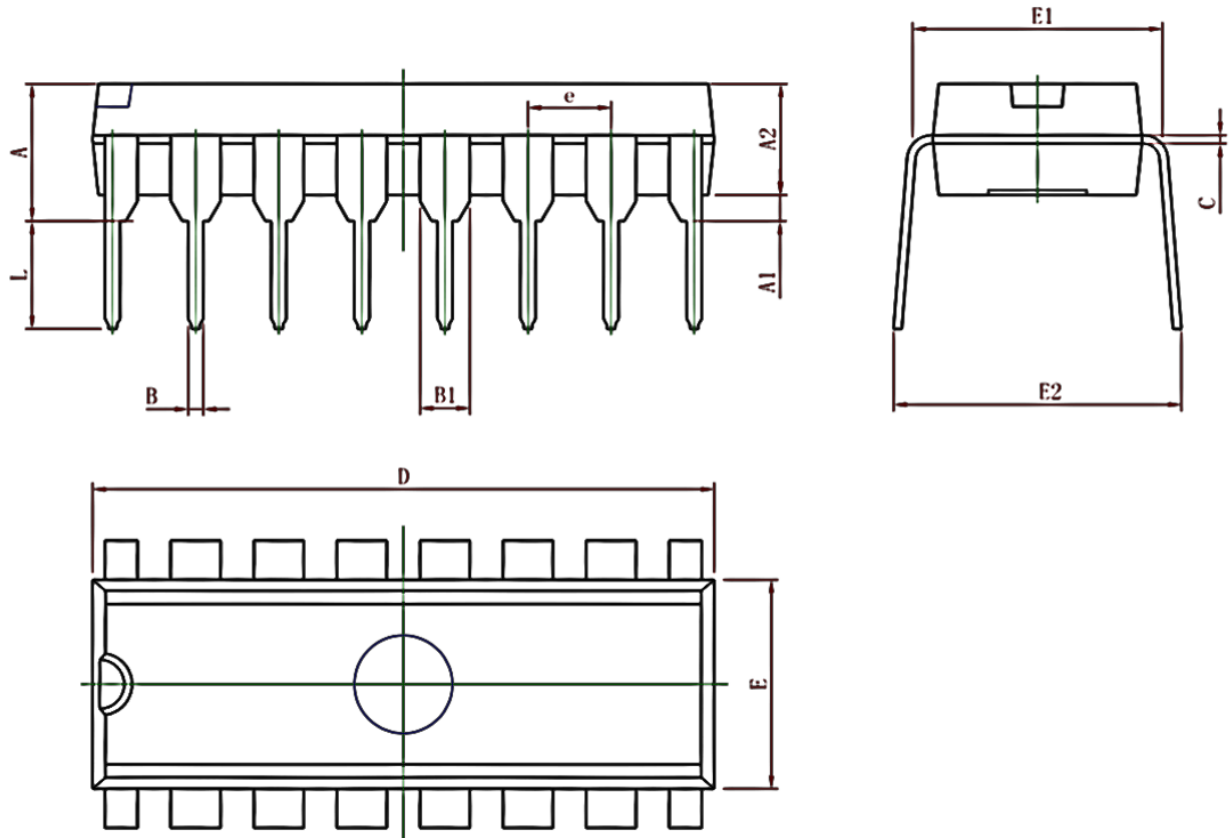

Symbol	Dimensions In Millimeters		Dimensions In Inches	
	Min.	Max.	Min.	Max.
A	3.710	4.310	0.146	0.170
A1	0.510	-	0.020	-
A2	3.200	3.600	0.126	0.142
B	0.380	0.570	0.015	0.022
B1	1.524 REF.		0.060 REF.	
C	0.204	0.360	0.008	0.014
D	18.800	19.200	0.740	0.756
E	6.200	6.600	0.244	0.260
E1	7.320	7.974	0.288	0.314
E2	8.400	9.000	0.331	0.354
e	2.540 REF.		0.100 REF.	
L	3.000	3.600	0.118	0.142

Important Notice

XLSEMI reserve the right to make modifications, enhancements, improvements, corrections or other changes without notice at any time. XLSEMI does not assume any liability arising out of the application or use of any product described herein; neither does it convey any license under its patent rights, nor the rights of others. XLSEMI assumes no liability for applications assistance or the design of Buyers' products. Buyers are responsible for their products and applications using XLSEMI components. To minimize the risks associated with Buyers' products and applications, Buyers should provide adequate design and operating safeguards. XLSEMI warrants performance of its products to the specifications applicable at the time of sale, in accordance with the warranty in XLSEMI's terms and conditions of sale of semiconductor products. Testing and other quality control techniques are used to the extent XLSEMI deems necessary to support this warranty. Except where mandated by applicable law, testing of all parameters of each component is not necessarily performed.

For the latest product information, go to www.xlsemi.com.