

2 × 35W 5A High Power Stereo Audio Power Amplifier

XL7292

Features

- Operation Voltage: 16V~40V
- Max. Output current capability up to 5A
- Max. Output power up to 2 × 35W
- Mute (“pop” free)
- Standby feature
- Built in output over power protection
- Built in output overvoltage protection
- Built in current limit protection function
- Built in thermal shutdown function
- Low quiescent current: 31mA
- Low Distortion: 0.02%, 1KHz, 1W
- Device HBM ESD Classification Level Class3B
- Available in FZIP11 package

Applications

- Car Audio Amplifiers
- Stage Sound
- Multimedia Speakers
- Open Mobile Sound System

General Description

XL7292 is a Class AB dual audio power amplifier optimized for high power and high efficiency. XL7292 has low quiescent current and minimizing system power consumption. XL7292 has excellent audio performance and achieved extremely low distortion levels even at 35W power levels.

XL7292 has mute function and standby function, built-in over power protection, output overvoltage protection, current limit protection function and thermal shutdown protection, which greatly improves the reliability and stability of the chip. The XL7292 achieves 25W@THD=0.1% of output power at an input voltage of $\pm 20V$ and a load impedance of 4 Ω or 8 Ω , and 35W@THD=10% at an input voltage of $\pm 20V$ and a load impedance of 4 Ω or 8 Ω .



Figure1. Package Type of XL7292

Pin Configurations

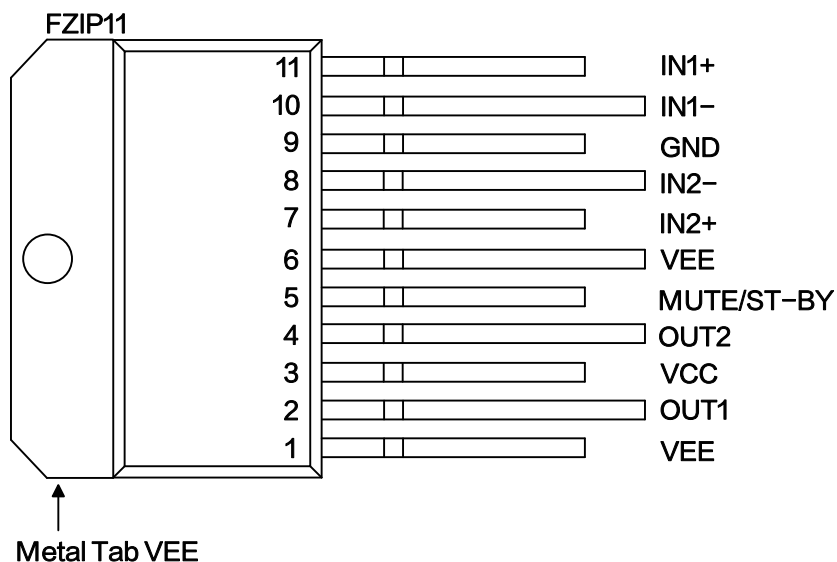

Figure2. Pin Configuration of XL7292

Table 1 Pin Description

Pin Number	Pin Name	Description
1	VEE	Ground/negative power supply side.
2	OUT1	Channel 1 Power amplifier output.
3	VCC	Positive power supply side.
4	OUT2	Channel 2 Power amplifier output.
5	MUTE/ST-BY	Mute or standby function pin.
6	VEE	Ground/negative power supply side.
7	IN2+	Channel 2 Isotropic terminal, audio signal input.
8	IN2-	Channel 2 Reverse terminal, negative feedback input.
9	GND	Ground pin.
10	IN1-	Channel 1 Reverse terminal, negative feedback input.
11	IN1+	Channel 1 Isotropic terminal, audio signal input.

2 × 35W 5A High Power Stereo Audio Power Amplifier

XL7292

Function Block

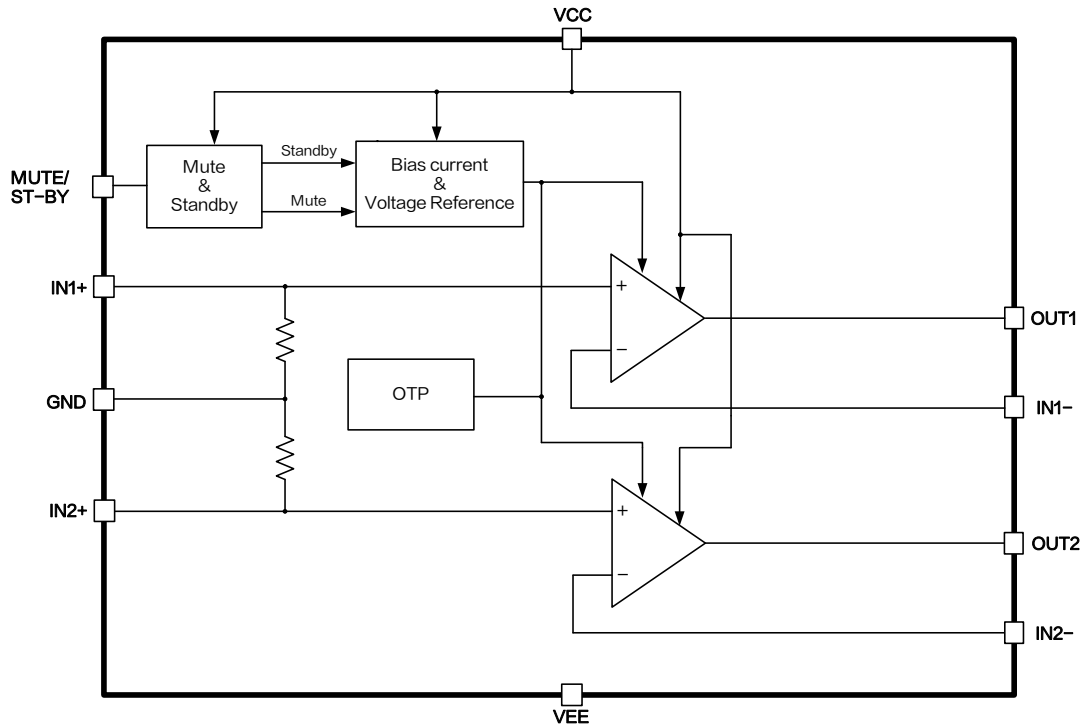

Figure3. Function Block Diagram of XL7292

Typical Application Circuit

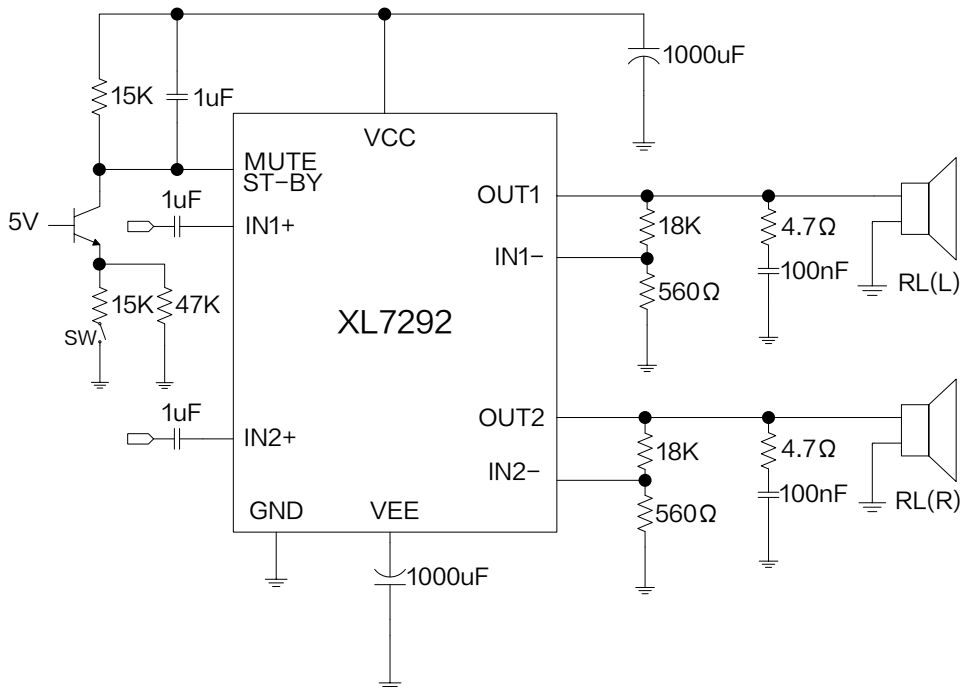

Figure 4. XL7292 Typical Application Circuit

2 × 35W 5A High Power Stereo Audio Power Amplifier

XL7292

Ordering Information

Order Information	Marking ID	Package Type	Eco Plan	Packing Type Supplied As
XL7292	XL7292	FZIP11	RoHS & HF	25 Units Per Tube

Absolute Maximum Ratings (Note1)

Parameter	Symbol	Value	Unit
Supply Voltage (Single Supply)	V_{CC}	48	V
Supply Voltage (Dual Supply)	V_S	± 24	V
Input Signal Voltage	V_{IN}	$V_{EE} \sim V_{CC}$	V
Thermal Resistance (FZIP11) (Junction to Ambient, No Heatsink, Free Air)	R_{JA}	43	$^{\circ}C/W$
Thermal Resistance (FZIP11) (Junction to Case)	R_{JC}	1.5	$^{\circ}C/W$
Power Dissipation ($T_c=70^{\circ}C$) (Note 2)	P_D	35	W
Operating Junction Temperature	T_J	150	$^{\circ}C$
Storage Temperature	T_{STG}	-40~150	$^{\circ}C$
Lead Temperature (Soldering, 10 sec)	T_{LEAD}	260	$^{\circ}C$
ESD(HBM)		>8000	V

Note1: Stresses greater than those listed under Maximum Ratings may cause permanent damage to the device. This is a stress rating only and functional operation of the device at these or any other conditions above those indicated in the operation is not implied. Exposure to absolute maximum rating conditions for extended periods may affect reliability.

Note2: For operation at case temperatures above $25^{\circ}C$, derating is performed based on a maximum junction temperature of $70^{\circ}C$ and a thermal resistance of $R_{JC}=1.5^{\circ}C/W$ (junction to case).

2 × 35W 5A High Power Stereo Audio Power Amplifier

XL7292

XL7292 Electrical Characteristics

$T_A = 25^\circ\text{C}$, $V_{CC}=20\text{V}$, $V_{EE}=-20\text{V}$, $R_L=8\Omega$, $A_V=33$, $f_0=1\text{KHz}$; system parameters test circuit figure4, unless otherwise specified.

Parameters	Symbol	Test Condition	Min.	Typ.	Max.	Unit
Supply Voltage (Single Supply)	V_{CC}		16		40	V
Supply Voltage (Dual Supply)	V_S		± 8		± 20	V
Mute Threshold	V_M		-7	-6	-5	V
Mute Attenuation	A_M			75		dB
Standby Threshold	V_{ST}		-3.5	-2.5	-1.5	V
Standby Attenuation	A_{ST}			110		dB
Standby Current	I_{ST}			9		mA
Quiescent Supply Current	I_Q	$P_o=0\text{W}$	25	31	40	mA
Output Power	P_o	THD=0.1%		25		W
		THD=10%		35		W
Total Harmonic Distortion	THD	$P_o=1\text{W}$		0.02		%
Offset Voltage	V_{FS}		-20		20	mV
Input Bias Current	I_B			0.5	1	μA
Open Loop Gain	A_{VO}	DC		80		dB
Crosstalk	C_T			70		dB
Input Resistance	R_i			20		$\text{K}\Omega$
Power Supply Rejection Ratio	PSRR			75		dB
Max Slew Rate	SR			6		V/ μs
Current Limit	I_L	$V_{OUT}=V_S-10\text{V}$		5		A
Total Input Noise	e_N	$f_0=20\text{Hz}\sim 22\text{KHz}$		4		μV
Thermal Shutdown Temperature	T_{SD}			165		$^\circ\text{C}$
Thermal Shutdown Hysteresis	T_D			40		$^\circ\text{C}$

Typical Performance Characteristics

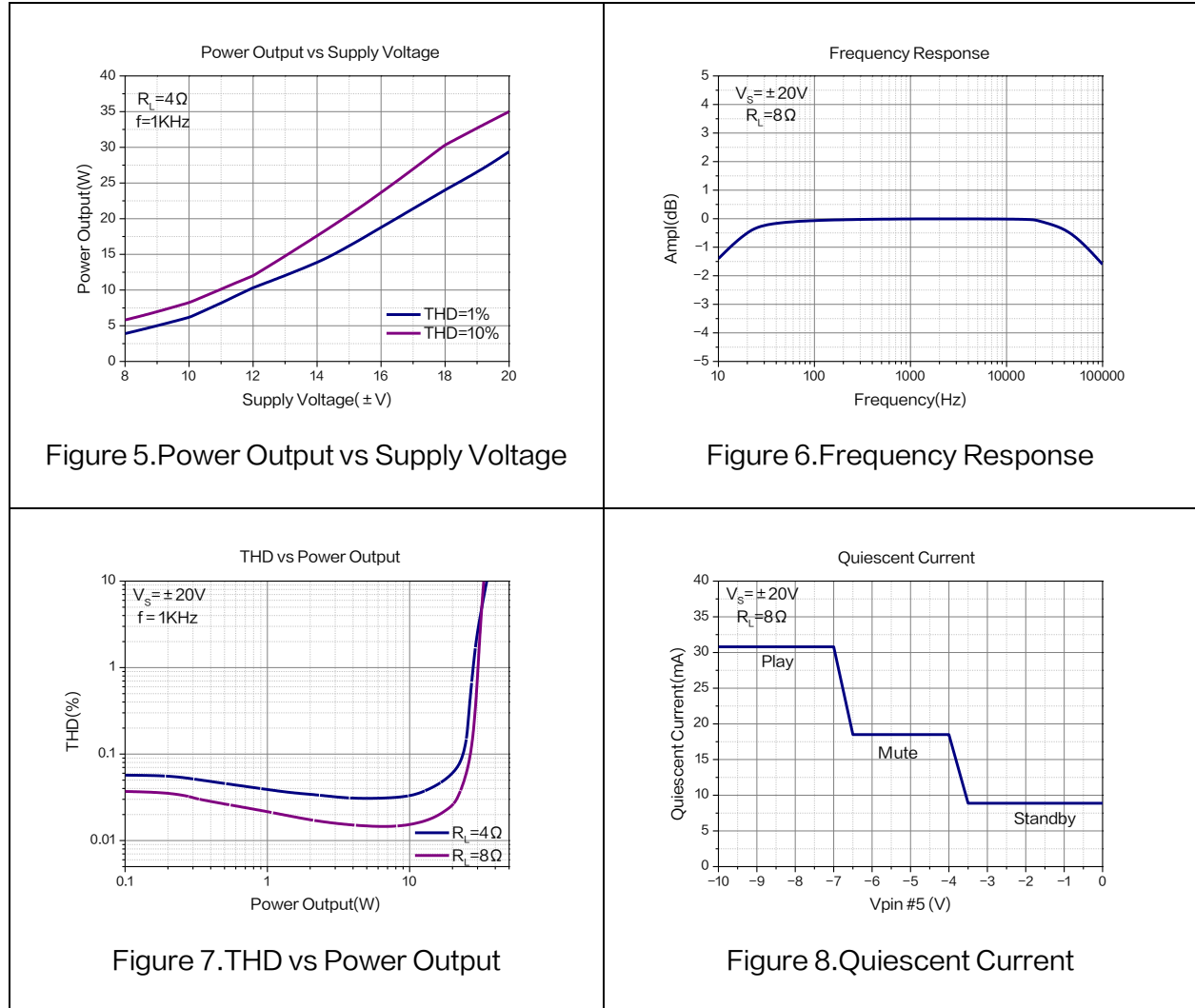

2 × 35W 5A High Power Stereo Audio Power Amplifier

XL7292

Package Information

FZIP11

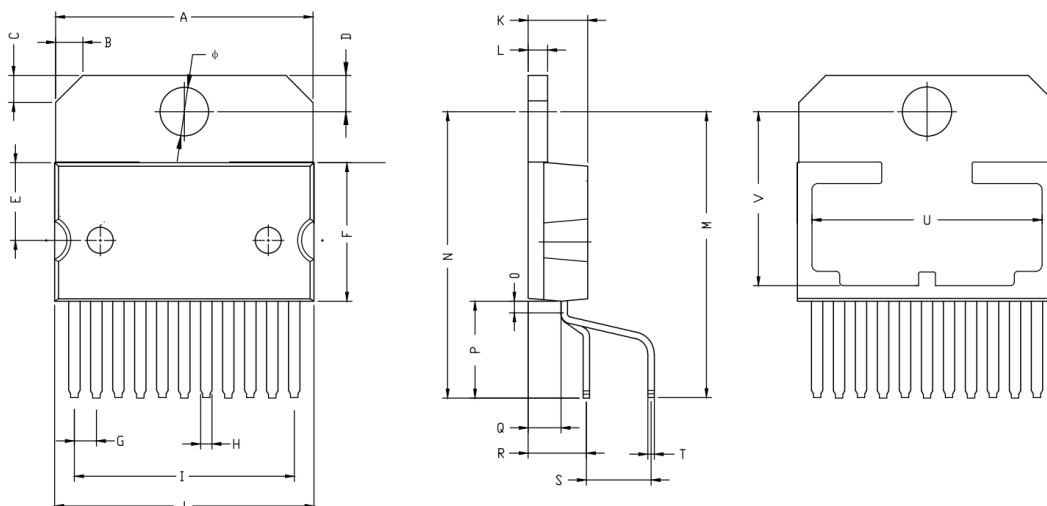

Symbol	Dimensions In Millimeters			Dimensions In Inches		
	Min.	Nom.	Max.	Min.	Nom.	Max.
A	19.85	19.90	19.95	0.781	0.783	0.785
B	1.80	2.10	2.40	0.070	0.083	0.094
C	1.80	2.10	2.40	0.070	0.083	0.094
D	2.75	2.80	2.85	0.108	0.110	0.112
E	5.90	6.00	6.10	0.232	0.236	0.240
F	10.60	10.70	10.80	0.417	0.421	0.425
G	-	1.70	-	-	0.067	-
H	-	0.90	-	-	0.035	-
I	-	17.00	-	-	0.669	-
J	20.00	20.05	20.10	0.787	0.789	0.791
K	4.55	4.60	4.65	0.179	0.181	0.183
L	-	1.50	-	-	0.059	-
M	22.00	22.10	22.60	0.866	0.870	0.890
N	22.00	22.14	22.64	0.866	0.872	0.891
O	-	0.90	-	-	0.035	-
P	-	7.50	-	-	0.295	-
Q	-	2.54	-	-	0.100	-
R	4.25	4.50	4.75	0.167	0.177	0.187
S	4.75	5.00	5.25	0.187	0.197	0.207
T	-	0.50	-	-	0.020	-
U	17.70	17.80	-	0.696	0.700	-
V	13.00	13.50	-	0.512	0.531	-
φ	-	3.75	-	-	0.148	-

2 × 35W 5A High Power Stereo Audio Power Amplifier	XL7292
---	---------------

Important Notice

XLSEMI reserve the right to make modifications, enhancements, improvements, corrections or other changes without notice at any time. XLSEMI does not assume any liability arising out of the application or use of any product described herein; neither does it convey any license under its patent rights, nor the rights of others. XLSEMI assumes no liability for applications assistance or the design of Buyers' products. Buyers are responsible for their products and applications using XLSEMI components. To minimize the risks associated with Buyers' products and applications, Buyers should provide adequate design and operating safeguards. XLSEMI warrants performance of its products to the specifications applicable at the time of sale, in accordance with the warranty in XLSEMI's terms and conditions of sale of semiconductor products. Testing and other quality control techniques are used to the extent XLSEMI deems necessary to support this warranty. Except where mandated by applicable law, testing of all parameters of each component is not necessarily performed.

For the latest product information, go to www.xlsemi.com.