

Features

- Operation Voltage: 2.5V~25V
- Directly Drive 1~8 Series LED
- Shutdown Current: 3uA
- Fixed 1.2MHz Switching Frequency
- 1A Constant Output Current Capability
- Built in High Frequency Power Transistor
- Built in Schottky Diode
- High Efficiency up to 88%
- Excellent line and load regulation
- EN PIN TTL ON/OFF capability
- Dimming Control Using a PWM Signal in EN PIN
- Boost or SEPIC Topologies
- Built in LED open circuit protection function
- Built in thermal shutdown function
- Device HBM ESD Classification Level Class3A
- Available in SOP8-EP package

General Description

XL6102 is a built in high frequency power transistor and Schottky diode Boost LED constant current driver, fixed 1.2MHz frequency PWM, can support input operating voltage range of 2.5V~25V. XL6102 has high precision constant current output to drive the LED, and built in frequency compensation circuitry allows the use of small external components at a price suitable for lowering the cost of the entire power supply system and reduce the printed circuit board space. The low feedback voltage of 200mV reduces the power consumption of the external sampling resistor, and the EN pin supports both TTL ON/OFF and PWM dimming from 0 to 100%. Suitable for very low quiescent current and ultra-small size applications.

Applications

- Screen Backlight LED Driver
- Wearable Portable Electronic Devices
- Digital Cameras
- PDAs and Other Handheld Devices
- Auxiliary Displays

Typical application schematic

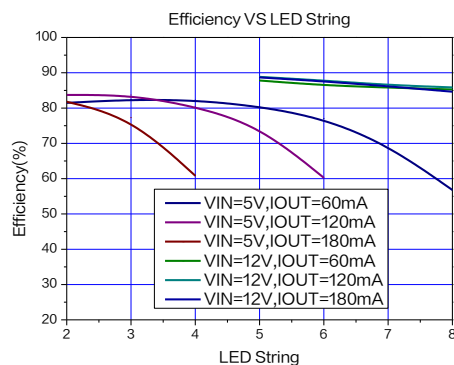
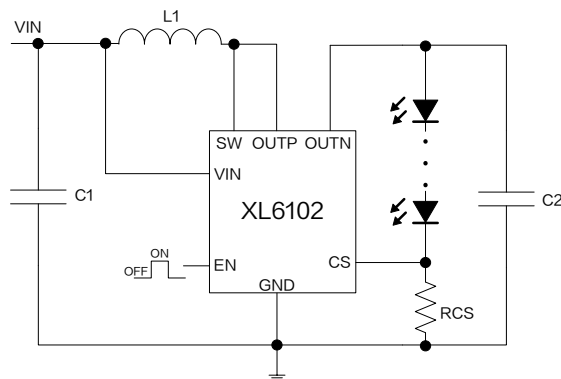

Figure1. XL6102 Typical application schematic and efficiency curve

Pin Configurations

VIN	1	8	SW
NC	2	7	OUTP
OUTN	3	6	GND
EN	4	5	CS

The Exposed PAD is GND

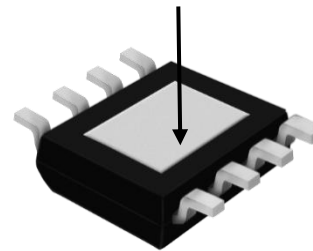

Figure2. Pin Configuration of XL6102

Table 1. Pin Description

Pin Number	Pin Name	Description
1	VIN	Supply Voltage Input Pin. XL6102 operates from 2.5V to 25V DC voltage. Bypass Vin to GND with a suitably large capacitor to eliminate noise on the input.
2	NC	No Connected.
3	OUTN	Output Pin. Internal Schottky diode cathode Pin.
4	EN	Enable Pin. Drive EN pin high to turn on the device, drive it low to turn it off. Floating is default high. Connect to a PWM signal to achieve LEDs brightness dimming.
5	CS	Output constant current sense Pin. The CS reference voltage is 200mV.
6	GND	Ground Pin.
7	OUTP	Internal Schottky diode anode Pin.
8	SW	Power Switch Pin.

Ordering Information

Order Information	Marking ID	Package Type	Eco Plan	Packing Type Supplied As
XL6102	XL6102	SOP8-EP	RoHS & HF	4000 Units on Reel

Function Block

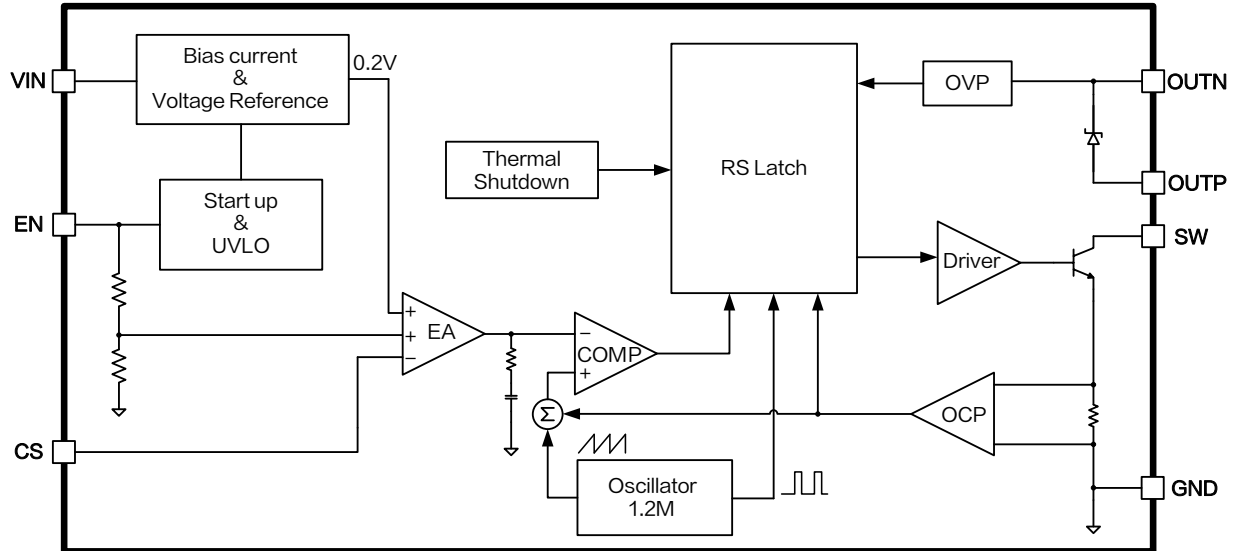

Figure3. Function Block Diagram of XL6102

Absolute Maximum Ratings (Note1)

Parameter	Symbol	Value	Unit
Input Voltage	V_{IN}	-0.3~32	V
EN Pin Voltage	V_{EN}	-0.3~ V_{IN}	V
Current Sense Pin Voltage	V_{CS}	-0.3~ V_{IN}	V
Switch Pin Voltage	V_{SW}	-0.3~40	V
OUTN Pin Voltage	V_{OUTN}	-0.3~40	V
Power Dissipation	P_D	250	mW
Thermal Resistance (SOP8-EP) (Junction to Ambient, No Heatsink, Free Air)	R_{JA}	60	°C/W
Maximum Junction Temperature	T_J	-40~150	°C
Operating Junction Temperature	T_J	-40~125	°C
Storage Temperature	T_{STG}	-65~150	°C
Lead Temperature (Soldering, 10 sec)	T_{LEAD}	260	°C
ESD (HBM)		>4000	V

Note1: Stresses greater than those listed under Maximum Ratings may cause permanent damage to the device. This is a stress rating only and functional operation of the device at these or any other conditions above those indicated in the operation is not implied. Exposure to absolute maximum rating conditions for extended periods may affect reliability.

1A 1.2MHz 30V Built in SBD Boost LED Constant Current Driver

XL6102

XL6102 Electrical Characteristics

T_A = 25°C; system parameters test circuit figure5, unless otherwise specified.

Symbol	Parameter	Test Condition	Min.	Typ.	Max.	Unit
V _{CS}	Current Sense Voltage	V _{IN} =5V, V _{OUT} =9.9V I _{LED} =20mA	194	200	206	mV
η	Efficiency	V _{IN} =5V, V _{OUT} =13.2V I _{LED} =20mA	-	79.1	-	%
η	Efficiency	V _{IN} =12V, V _{OUT} =16.5V I _{LED} =120mA	-	88.8	-	%

Electrical Characteristics (DC Parameters)

T_A=25°C, V_{IN}=3V; system parameters test circuit figure4, unless otherwise specified.

Parameters	Symbol	Test Condition	Min.	Typ.	Max.	Unit
Input operation voltage	V _{IN}		2.5		25	V
Shutdown Supply Current	I _S	V _{EN} =0V OUTN flowing		3		uA
Quiescent Supply Current	I _Q	V _{CS} =2V		2.3		mA
Oscillator Frequency	F _{OSC}		0.96	1.20	1.44	MHz
Switch Current Limit	I _L	V _{CS} =0V		1		A
Switch V _{CE} Saturation Voltage	V _{SAT}	I _{SW} =300mA		0.3		V
Schottky Forward Drop	V _F	I _F =300mA		0.8		V
EN Pin Threshold	V _{EN,H}	High(ON)	2.0			V
	V _{EN,L}	Low(OFF)			0.5	
Max. Duty Cycle	D _{MAX}	V _{CS} =0V		90		%
Over Voltage Protection	V _{OUT}	OUTN OPEN (V _{CS} =0V)		30		V
Thermal Shutdown Temperature	T _{SD}			150		°C

Typical System Application–Single Li Battery to Drive LED

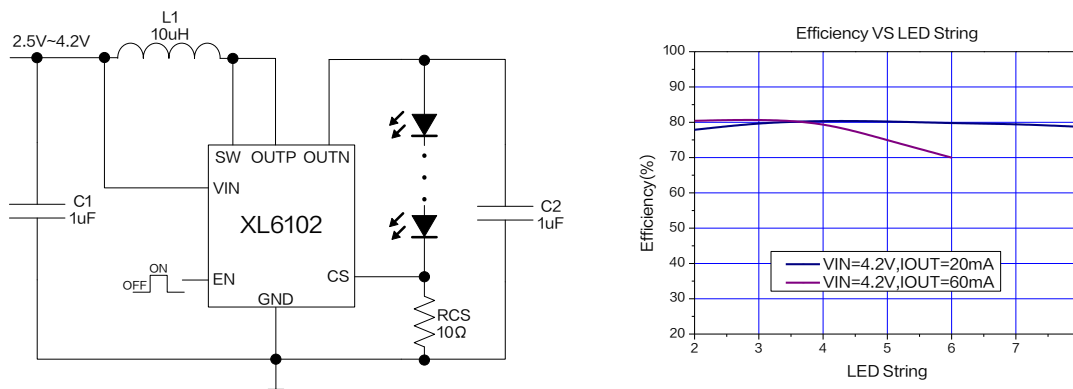

Figure4. XL6102 System Application and efficiency curve

Table 2. Figure4 Typical System Application Schematic Boom

Qty	Ref Des	Description	Mfg Part Number	Mfg
1	L1	10uH,1.1A,Inductor,3*3	YHNR3015-100M	YJYCOIN
2	C1,C2	1uF,50V,Ceramic,X7R,0603	0603B105K500NT	Fenghua
1	RCS	10Ω,1%,1/8W,Thick Film,0805	RS-05K100FT	Fenghua

Typical System Application–Two Li Batteries to Drive LED

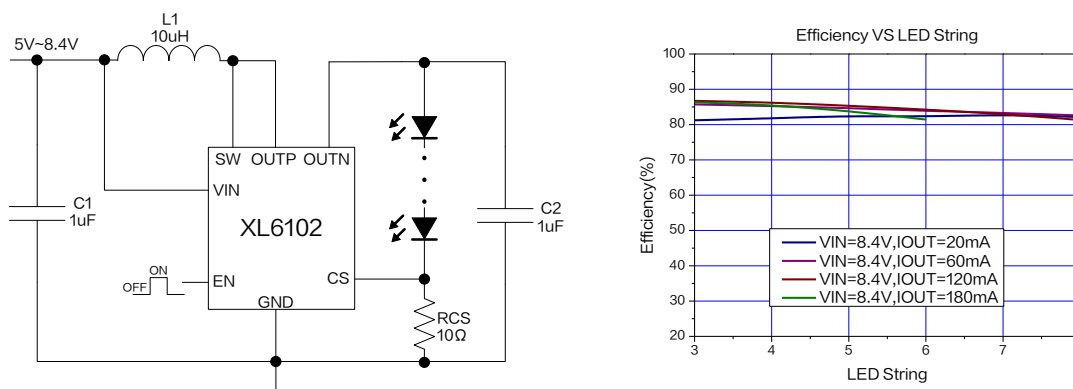

Figure5. XL6102 System Application and efficiency curve

Table 3. Figure5 Typical System Application Schematic Boom

Qty	Ref Des	Description	Mfg Part Number	Mfg
1	L1	10uH,1.1A,Inductor,3*3	YHNR3015-100M	YJYCOIN
2	C1,C2	1uF,50V,Ceramic,X7R,0603	0603B105K500NT	Fenghua
1	RCS	10Ω,1%,1/8W,Thick Film,0805	RS-05K100FT	Fenghua

Typical System Application– BOOST Topology to Drive LED

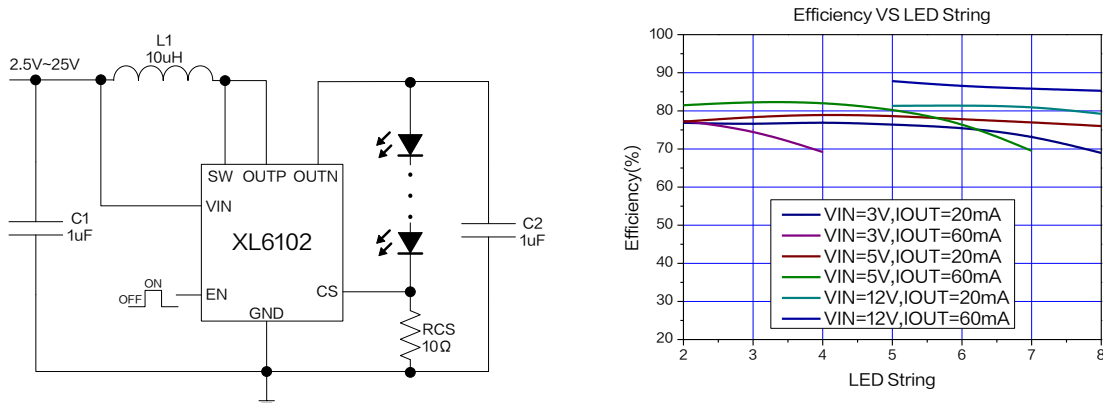

Figure6. XL6102 System Application and efficiency curve

Table 4. Figure6 Typical System Application Schematic Boom

Qty	Ref Des	Description	Mfg Part Number	Mfg
1	L1	10uH,1.1A,Inductor,3*3	YHNR3015-100M	YJYCOIN
2	C1,C2	1uF,50V,Ceramic,X7R,0603	0603B105K500NT	Fenghua
1	RCS	10Ω,1%,1/8W,Thick Film,0805	RS-05K100FT	Fenghua

Typical System Application– SEPIC Topology to Drive LED

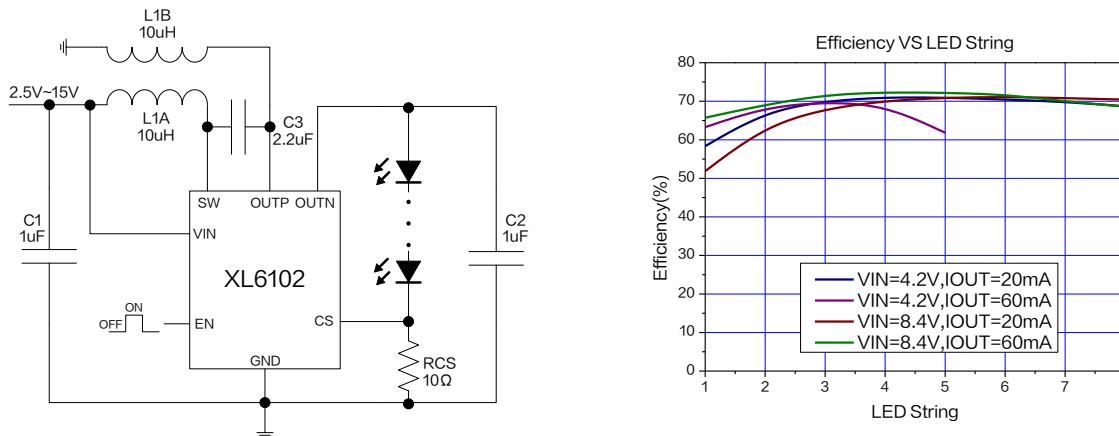

Figure7. XL6102 System Application and efficiency curve

Table 5. Figure7 Typical System Application Schematic Boom

Qty	Ref Des	Description	Mfg Part Number	Mfg
2	L1A,L1B	10uH,1.1A,Inductor,3*3	YHNR3015-100M	YJYCOIN
2	C1,C2	1uF,50V,Ceramic,X7R,0603	0603B105K500NT	Fenghua
1	C3	2.2uF,50V,Ceramic,X7R,0805	0805X225K500NT	Fenghua
1	RCS	10Ω,1%,1/8W,Thick Film,0805	RS-05K100FT	Fenghua

Typical System Application– PWM dimming circuit

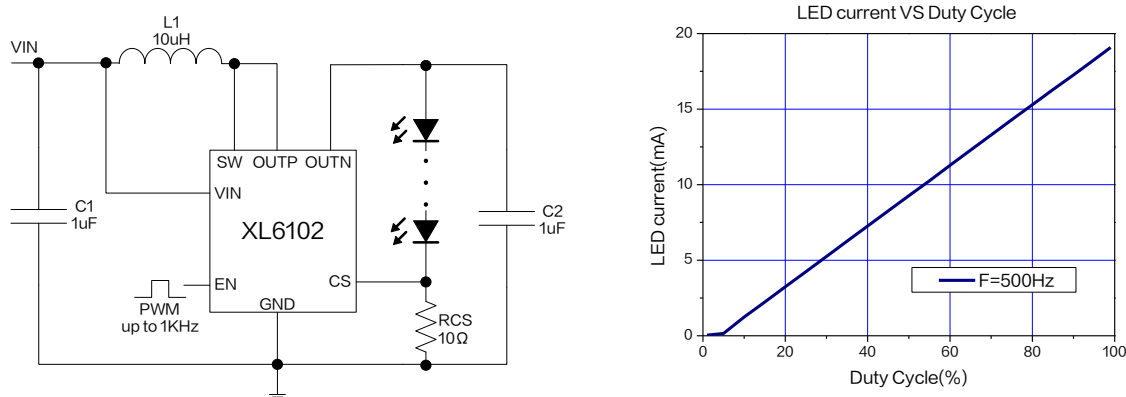

Figure 8. XL6102 Dimming circuit and PWM dimming curve

Typical Characteristics (LED forward voltage V_F is 3.3V at $I_F=20mA$, unless otherwise noted.)

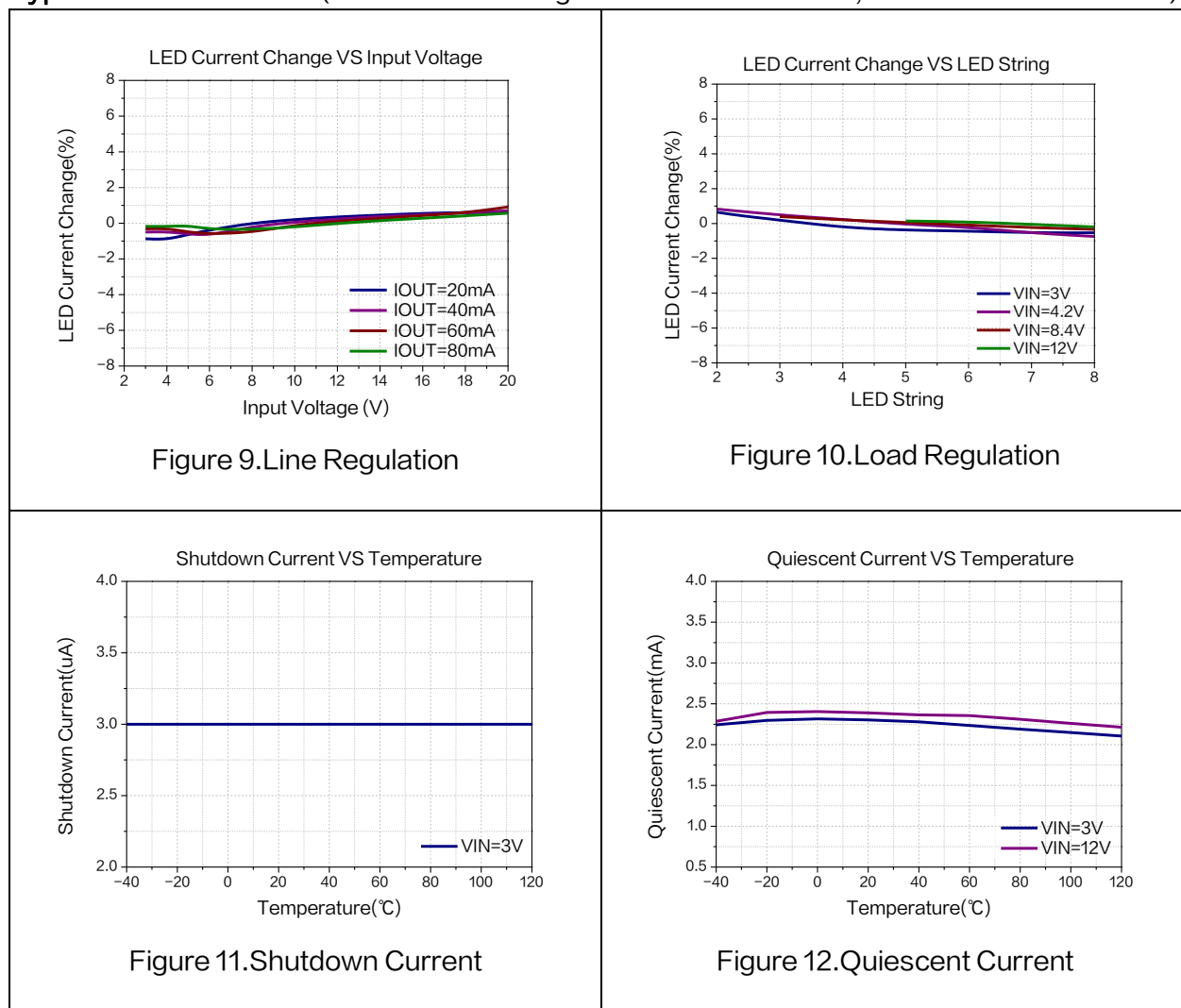

Figure 9. Line Regulation

Figure 10. Load Regulation

Figure 11. Shutdown Current

Figure 12. Quiescent Current

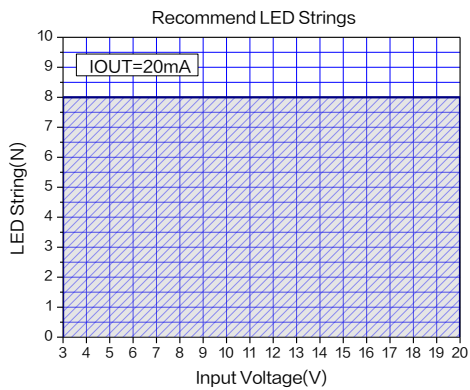

Figure 13.Max LED Strings($I_{OUT}=20mA$)

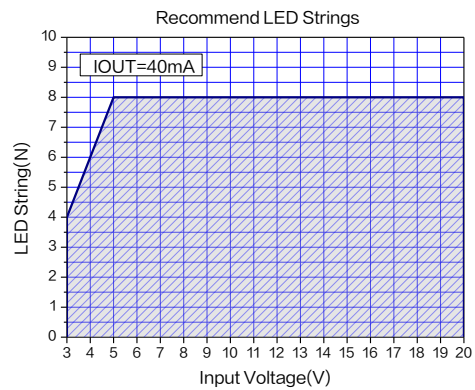

Figure 14.Max LED Strings($I_{OUT}=40mA$)

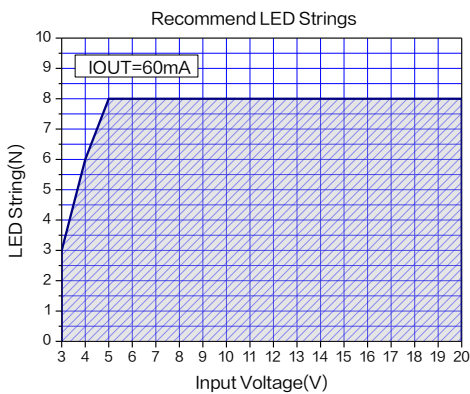

Figure 15.Max LED Strings($I_{OUT}=60mA$)

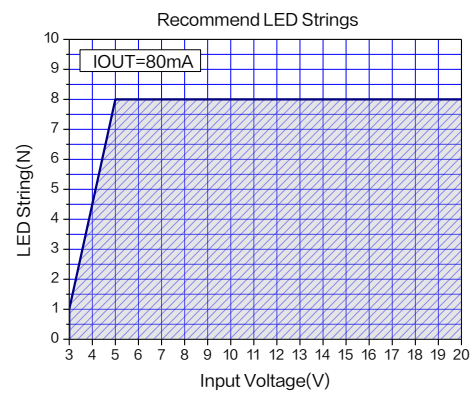

Figure 16.Max LED Strings($I_{OUT}=80mA$)

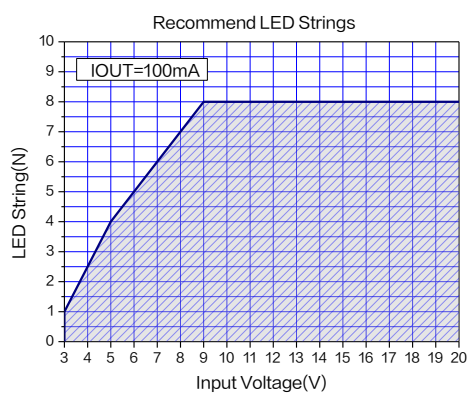

Figure 17.Max LED Strings($I_{OUT}=100mA$)

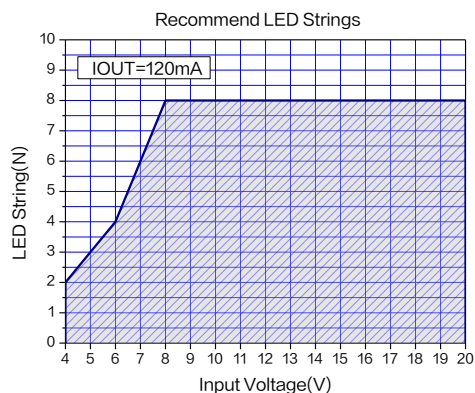
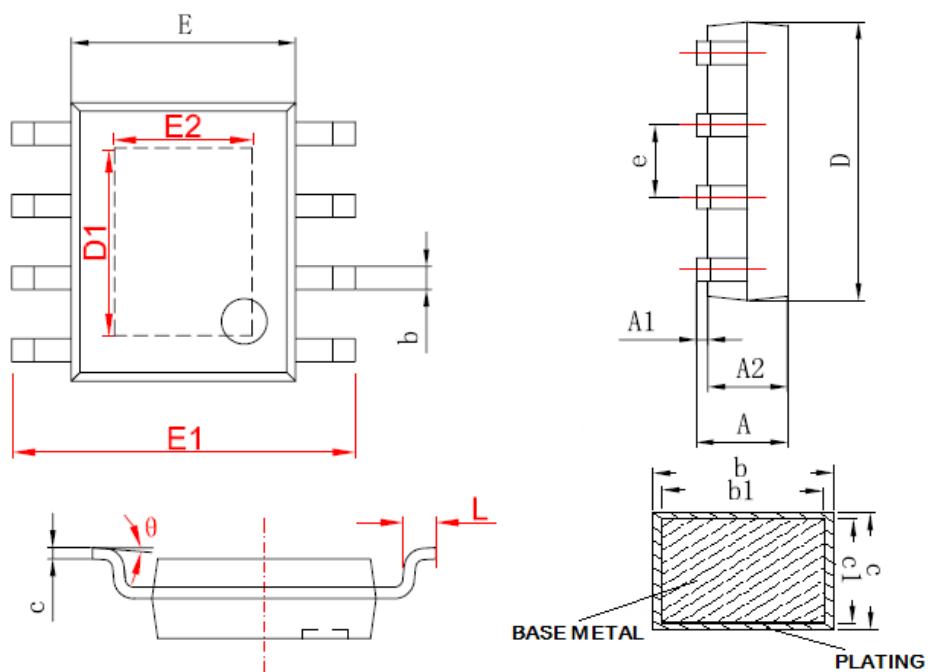

Figure 18.Max LED Strings($I_{OUT}=120mA$)

Package Information

SOP8-EP



Symbol	Dimensions In Millimeters		Dimensions In Inches	
	Min.	Max.	Min.	Max.
A	1.350	1.750	0.053	0.069
A1	0.000	0.150	0.000	0.006
A2	1.250	1.650	0.049	0.065
b	0.306	0.510	0.012	0.020
b1	0.296	0.480	0.011	0.019
c	0.170	0.250	0.006	0.010
c1	0.170	0.230	0.006	0.009
D	4.700	5.100	0.185	0.200
D1	2.650	3.467	0.104	0.136
E	3.800	4.000	0.150	0.157
E1	5.800	6.200	0.228	0.244
E2	1.930	2.534	0.076	0.100
e	1.140	1.400	0.045	0.055
L	0.450	0.800	0.017	0.031
θ	0°	8°	0°	8°

1A 1.2MHz 30V Built in SBD Boost LED Constant Current Driver	XL6102
--	--------

Important Notice

XLSEMI reserve the right to make modifications, enhancements, improvements, corrections or other changes without notice at any time. XLSEMI does not assume any liability arising out of the application or use of any product described herein; neither does it convey any license under its patent rights, nor the rights of others. XLSEMI assumes no liability for applications assistance or the design of Buyers' products. Buyers are responsible for their products and applications using XLSEMI components. To minimize the risks associated with Buyers' products and applications, Buyers should provide adequate design and operating safeguards. XLSEMI warrants performance of its products to the specifications applicable at the time of sale, in accordance with the warranty in XLSEMI's terms and conditions of sale of semiconductor products. Testing and other quality control techniques are used to the extent XLSEMI deems necessary to support this warranty. Except where mandated by applicable law, testing of all parameters of each component is not necessarily performed.

For the latest product information, go to www.xlsemi.com.